



INSTRUCTIONS

This manual contains important warnings and information.
READ AND RETAIN FOR REFERENCE

U.S. PATENT NO. 4,323,741, 4,397,610
PATENTED 1983, CANADA
AND OTHER PATENTS PENDING

ELECTRIC, 120 VAC

ULTIMATE[®] Plus+ 1000 Airless Paint Sprayer

3000 psi (210 bar) Maximum Working Pressure

Model 820-210, Series A

Basic sprayer only

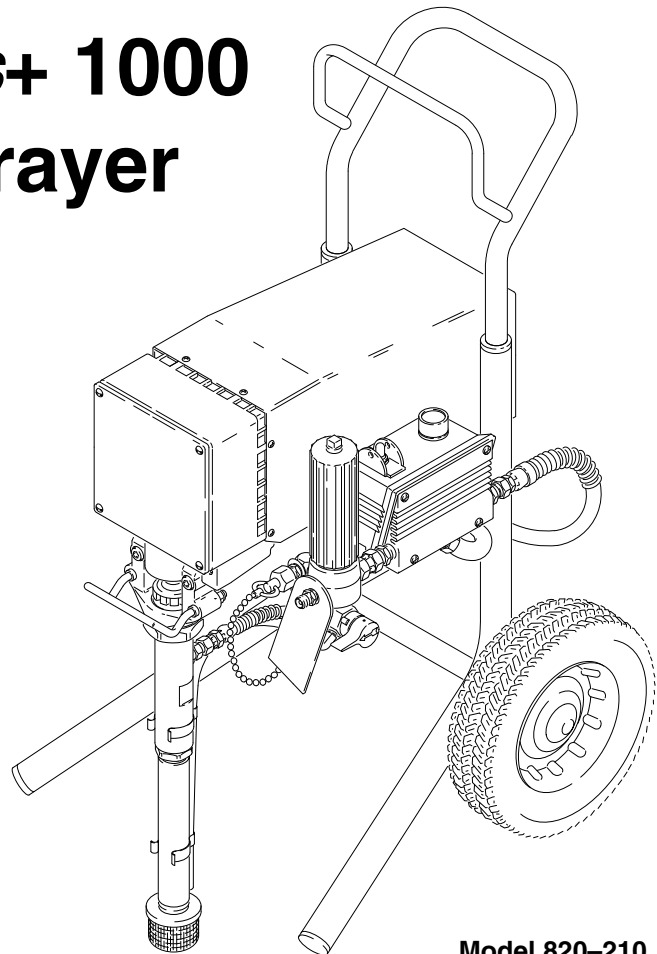

Model 820-210

04284

Table of Contents

| | | | |
|--|----|--|----|
| Introduction | 2 | Drive Housing Replacement | 26 |
| Warnings | 4 | Motor Replacement | 28 |
| Setup | 7 | Displacement Pump Repair | 30 |
| Startup | 9 | Parts Drawing – Sprayer | 34 |
| Shutdown and Care | 11 | Parts List – Sprayer | 35 |
| Flushing | 12 | Parts Drawing and List – Displacement Pump | 36 |
| Troubleshooting | 13 | Parts Drawing – Pressure Control | 37 |
| Spin Test | 18 | Parts List – Pressure Control | 37 |
| General Repair Information | 19 | Wiring Diagram | 38 |
| Motor Brush Replacement | 20 | Accessories | 39 |
| Power Supply Cord Replacement | 21 | Technical Data | 39 |
| On/Off Switch Replacement | 22 | Dimensions | 39 |
| Pressure Control Replacement | 23 | Warranty And Disclaimers | 40 |
| Bearing Housing & Connecting Rod Replacement | 25 | | |

Introduction

ULTIMATE® Plus+ 1000 BASIC COMPONENTS

Your new sprayer functions and operates differently than other airless paint sprayers. This section will help you become familiar with the sprayer before operating it.

Pressure Control

The pressure control includes an ON/OFF switch for the sprayer, a pressure adjusting control knob and a freeze resistant pressure sensing device. The function of the pressure control is to control the motor speed so that the sprayer maintains constant fluid pressure at the pump outlet.

Pressure Drain Valve

The pressure drain valve provides pressure relief of the sprayer. In the forward position, the drain valve is closed and allows normal sprayer operation. In the downward position, the pressure drain valve relieves the pressure in the system. The pressure drain valve will also open automatically in the case of a control overpressure failure.

Motor

The DC motor has sealed bearings and replaceable motor brushes. It drives the displacement pump at the rate needed to supply sufficient paint volume at the selected pressure. Working together, the pressure control and motor cause the pump to cycle whenever there is fluid or pressure demand. When the pump is cycling, the motor sounds like an automobile starter cranking. When the pump is not cycling, the motor may hum intermittently until the fluid pressure stabilizes, then the motor will shut itself off. However, there will still be power to the sprayer and it will stay pressurized and ready to use until you manually shut it off and relieve pressure.

Because the motor is DC, it is less sensitive to low voltage or voltage fluctuations than an AC motor, and a 12 gauge or larger extension cord of up to 300 ft. (90 m) can be used without performance loss.

Drive Assembly

The sealed drive assembly transfers power from the DC motor to the displacement pump.

Displacement Pump

The positive displacement, volume-balanced pump provides equal fluid delivery on both the up and down pump strokes. The pump has a wet-cup which, when filled with Graco Throat Seal Liquid, helps prevent damage to the throat packings and piston rod.

Fluid Filter

The fluid filter strains the paint to help avoid clogs in the hose and spray tip. The filter includes a reusable element and has a pressure drain valve for manually relieving fluid pressure.

Hoses

The grounded, nylon spray hoses have spring guards on both ends. The 50 ft. (15.2 m) hose has a 1/4 in. ID. The 3 ft. (0.9 m), 3/16 in. ID hose provides more flexible gun movement. The nylon hose material acts as a pulsation dampener to absorb pressure fluctuations.

Spray Gun & RAC IV DripLess Tip Guard

Graco high pressure spray guns have a safety latch which prevents accidental triggering when it is engaged. See **T** in Fig. 1. The gun provided with the sprayer also has a filter for final paint straining. The Reverse-A-Clean IV SwitchTip uses high pressure fluid to remove clogs from the spray tip without removing it from the gun. The Reverse-A-Clean IV DripLess tip guard is a safety feature which helps reduce the risk of fluid injection injury.

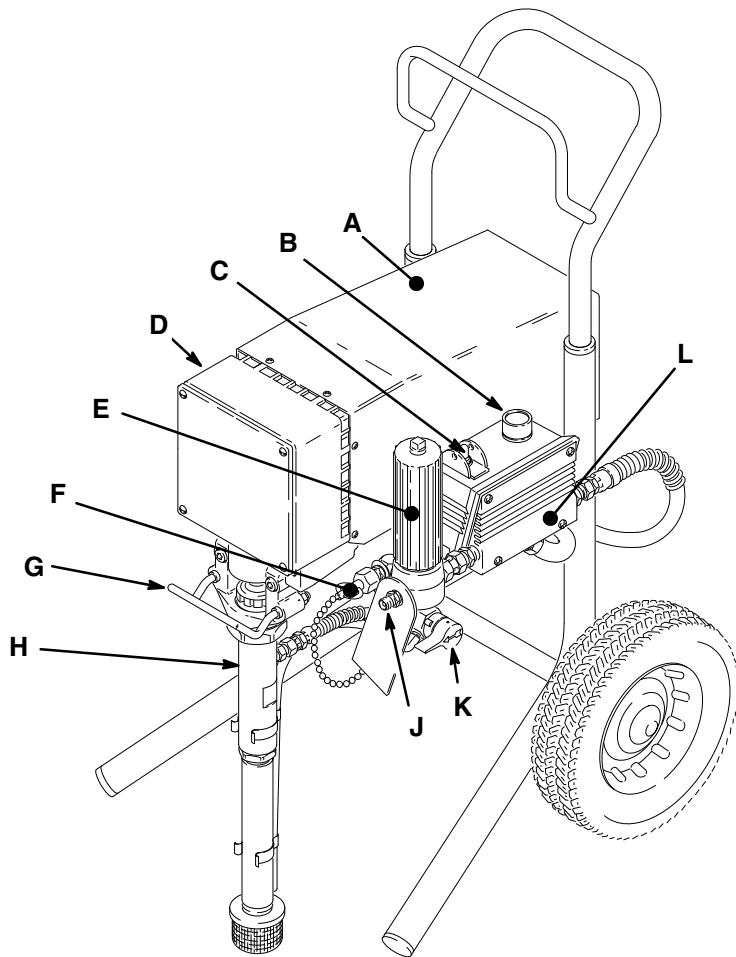

04284

Fig. 1

| | | |
|----------|-------------------------|---|
| A | Motor | DC motor, 120 Vac, 15A, 1 phase |
| B | Pressure Adjusting Knob | Controls fluid outlet pressure |
| C | ON/OFF Switch | Power switch that controls 120 Vac main power to sprayer |
| D | Drive Assembly | Transfers power from DC motor to the displacement pump |
| E | Fluid Filter | Final filter of fluid between source and spray gun |
| F | Secondary Fluid Outlet | Second spray gun operation is connected here |
| G | Pail Hanger | Container for fluid to be sprayed may be hung here |
| H | Displacement Pump | Transfers fluid to be sprayed from source through spray gun |
| J | Primary Fluid Outlet | Single spray gun operation is connected here |
| K | Pressure Drain Valve | Relieves fluid outlet pressure when open |
| L | Pressure Control | Controls motor speed to maintain fluid outlet pressure at displacement pump outlet. Works with pressure adjusting knob. |

Symbols

Warning Symbol



This symbol alerts you to the possibility of serious injury or death if you do not follow the instructions.

Caution Symbol



This symbol alerts you to the possibility of damage to or destruction of equipment if you do not follow the instructions.

WARNING



INSTRUCTIONS

EQUIPMENT MISUSE HAZARD

Equipment misuse can cause the equipment to rupture or malfunction and result in serious injury.

- This equipment is for professional use only.
- Read all instruction manuals, tags, and labels before operating the equipment.
- Use the equipment only for its intended purpose. If you are not sure, call Graco Technical Assistance at 1-800-543-0339.
- Do not alter or modify this equipment.
- Check equipment daily. Repair or replace worn or damaged parts immediately.
- Do not exceed the maximum working pressure of the lowest rated system component. Refer to the **Technical Data** on page 39 for the maximum working pressure of this equipment.
- Use fluids and solvents which are compatible with the equipment wetted parts. Refer to the **Technical Data** section of all equipment manuals. Read the fluid and solvent manufacturer's warnings.
- Do not use hoses to pull equipment.
- Route hoses away from traffic areas, sharp edges, moving parts, and hot surfaces. Do not expose Graco hoses to temperatures above 82°C (180°F) or below -40°C (-40°F).
- Do not lift pressurized equipment.
- Comply with all applicable local, state, and national fire, electrical, and safety regulations.

WARNING



INJECTION HAZARD

Spray from the gun, leaks or ruptured components can inject fluid into your body and cause extremely serious injury, including the need for amputation. Fluid splashed in the eyes or on the skin can also cause serious injury.

- Fluid injected into the skin is a serious injury. The injury may look like just a cut, but it is a serious injury. Get immediate medical attention.
- Do not point the gun at anyone or at any part of the body.
- Do not put your hand or fingers over the spray tip.
- Do not stop or deflect leaks with your hand, body, glove or rag.
- Do not “blow back” fluid; this is not an air spray system.
- Always have the tip guard and the trigger guard on the gun when spraying.
- Check the gun diffuser operation weekly. Refer to the gun manual.
- Be sure the gun trigger safety operates before spraying.
- Lock the gun trigger safety when you stop spraying.
- Follow the **Pressure Relief Procedure** on page 13 if the spray tip clogs and before cleaning, checking or servicing the equipment.
- Tighten all fluid connections before operating the equipment.
- Check the hoses, tubes, and couplings daily. Replace worn or damaged parts immediately. Do not repair high pressure couplings; you must replace the entire hose.
- Fluid hoses must have spring guards on both ends, to help protect them from rupture caused by kinks or bends near the couplings.



TOXIC FLUID HAZARD

Hazardous fluid or toxic fumes can cause serious injury or death if splashed in the eyes or on the skin, inhaled, or swallowed.

- Know the specific hazards of the fluid you are using.
- Store hazardous fluid in an approved container. Dispose of hazardous fluid according to all local, state and national guidelines.
- Always wear protective eyewear, gloves, clothing and respirator as recommended by the fluid and solvent manufacturer.

⚠ WARNING



FIRE AND EXPLOSION HAZARD

Improper grounding, poor ventilation, open flames or sparks can cause a hazardous condition and result in a fire or explosion and serious injury.



- If there is any static sparking or you feel an electric shock while using this equipment, **stop spraying immediately**. Do not use the equipment until you identify and correct the problem.
- Provide fresh air ventilation to avoid the buildup of flammable fumes from solvents or the fluid being sprayed.
- Keep the spray area free of debris, including solvent, rags, and gasoline.
- Electrically disconnect all equipment in the spray area.
- Extinguish all open flames or pilot lights in the spray area.
- Do not smoke in the spray area.
- Do not turn on or off any light switch in the spray area while operating or if fumes are present.
- Do not operate a gasoline engine in the spray area.



MOVING PARTS HAZARD

Moving parts, such as the air motor piston, can pinch or amputate your fingers.

- Keep clear of all moving parts when starting or operating the pump.
- Before servicing the equipment, follow the **Pressure Relief Procedure** on page 13 to prevent the equipment from starting unexpectedly.

NOTE: This is an example of the DANGER label on your sprayer. This label is available in other languages, free of charge. See page 39 to order.

| ⚠ DANGER ⚠ | |
|---|--|
| FIRE AND EXPLOSION HAZARD | SKIN INJECTION HAZARD |
| <p>Spray painting, flushing or cleaning equipment with flammable liquids in confined areas can result in fire or explosion.</p> <p>Use outdoors or in extremely well ventilated areas. Ground equipment, hoses, containers and objects being sprayed.</p> <p>Avoid all ignition sources such as static electricity from plastic drop cloths, open flames such as pilot lights, hot objects such as cigarettes, arcs from connecting or disconnecting power cords or turning light switches on and off.</p> <p>Failure to follow this warning can result in death or serious injury.</p> | <p>Liquids can be injected into the body by high pressure airless spray or leaks – especially hose leaks.</p> <p>Keep body clear of the nozzle. Never stop leaks with any part of the body. Drain all pressure before removing parts. Avoid accidental triggering of gun by always setting safety latch when not spraying.</p> <p>Never spray without a tip guard.</p> <p>In case of accidental skin injection, seek immediate “Surgical Treatment”.</p> <p>Failure to follow this warning can result in amputation or serious injury.</p> |
| READ AND UNDERSTAND ALL LABELS AND INSTRUCTION MANUALS BEFORE USE | |

Setup

WARNING

To reduce the risk of serious injury from static sparking, injection, or over pressurization and rupture of the hose or gun, all hoses must be electrically conductive, the gun must have a tip guard, and each part must be rated for at least 3000 psi (210 bar) Maximum Working Pressure.

CAUTION

To avoid damaging the pressure control, which may result in poor equipment performance and component damage, follow these precautions:

1. Always use grounded, flexible spray hose at least 50 ft. (15 m) long.
2. Never use a wire braid hose as it is too rigid to act as a pulsation dampener.
3. Never install any shutoff device between the filter and the main hose. See Fig. 2.
4. Always use the main filter outlet for one gun operation. Never plug this outlet.

WARNING



FIRE AND EXPLOSION HAZARD

Proper electrical grounding is essential to reduce the risk of fire or explosion which can result in serious injury and property damage. Read the warning section **FIRE OR EXPLOSION HAZARD** on page 6 for more detailed grounding instructions.

NOTE: See Fig. 2 while doing the setup.

1. **Fill the packing nut/wet-cup** 1/3 full with Graco Throat Seal Liquid (TSL), supplied.
2. **Connect the gun, 3 ft. hose and 50 ft. hose.** Screw the assembly onto the outlet nipple. Don't use thread sealant and don't install the spray tip yet!
3. **Two gun hookup.** Unscrew the cap from the 1/4 npsm(m) secondary hose outlet. Connect a hose and gun to the outlet. Use a 1/4 in. ID, 50 ft. long (minimum) main hose. For more flexible gun movement, install a 3/16 in. ID, 3 ft. hose between the main hose and the gun.
4. **Check the Electrical Service.**

Two gun hookup. Unscrew the cap from the 1/4 npsm(m) secondary hose outlet. Connect a hose and gun to the outlet. Use a 1/4 in. ID, 50 ft. long (minimum) main hose. For more flexible gun movement, install a 3/16 in. ID, 3 ft. hose between the main hose and the gun.

 - a. Electrical requirements: 120 V AC, 60 Hz, 15 Amp (minimum).
 - b. Use a grounded electrical outlet located at least 20 ft. (6 m) from the spray area.
 - b. Do not remove the grounding prong of the power supply cord and do not use an adapter.
 - c. Extension cord specifications: 15 Amps, 3 wires, grounding type. (Long lengths reduce sprayer performance.)
5. **Plug in the sprayer.** Turn the ON/OFF switch OFF. Plug the cord into a grounded electrical outlet.
6. **Flush the pump** to remove the oil left in to protect pump parts after factory testing. See **Flushing** on page 12.
7. **Prepare the paint** according to the manufacturer's recommendations. Remove any paint skin. Stir the paint thoroughly. Strain the paint through a fine nylon mesh bag (available at most paint dealers) to remove particles that could clog the filter or spray tip. This is an important step for trouble-free paint spraying.

Setup

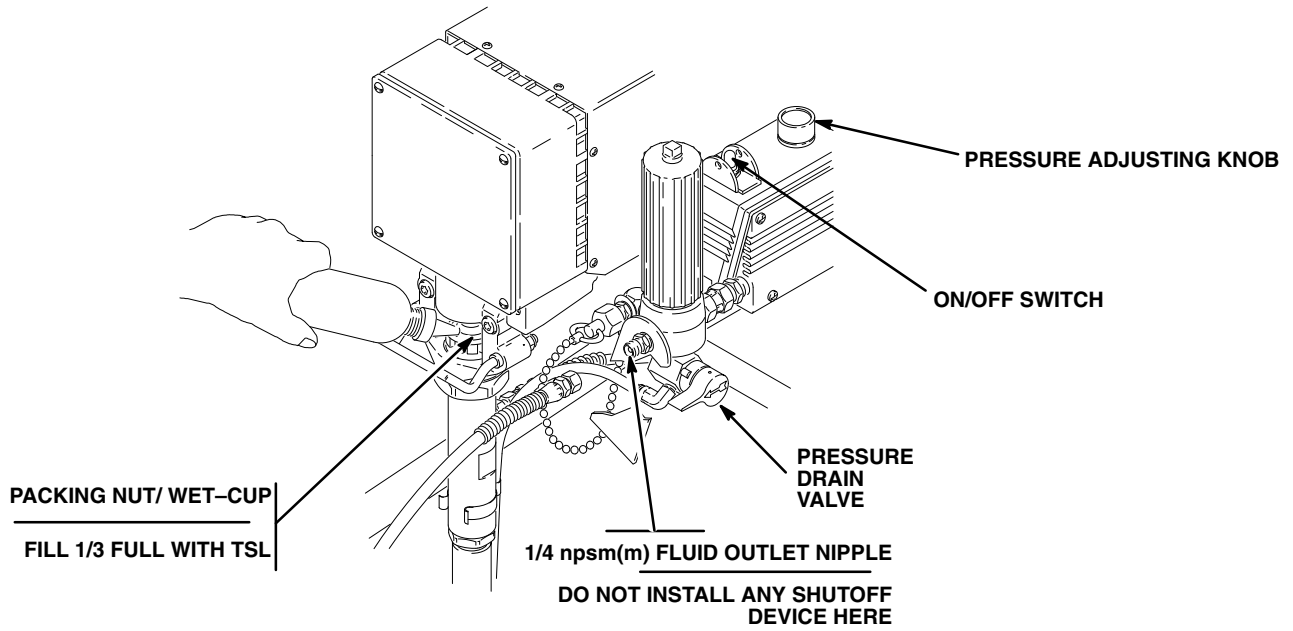

04288

Fig. 2

Startup

Use this procedure each time you start the sprayer to help ensure the sprayer is ready to operate and that you start it safely.

| | |
|---|--|
| ⚠ WARNING | |
|  | INJECTION HAZARD To reduce the risk of serious injury, follow the illustrated Pressure Relief Procedure warning on page 13 whenever you are instructed to relieve pressure. |

NOTE: Flush the sprayer if this is a first-time startup. See page 12.

NOTE: See Fig. 4 except where noted.

1. **Put the suction tube into the paint container.**
2. **Turn the pressure adjusting knob fully counterclockwise to zero pressure.**
3. **Plug in the sprayer.**

| |
|---|
| ⚠ CAUTION |
| Do not run the pump without fluid in it for more than 30 seconds to avoid damage to the displacement pump packings. |

| | |
|---|---|
| ⚠ WARNING | |
|  | FIRE AND EXPLOSION HAZARD To reduce the risk of static sparking and splashing when flushing, always remove the spray tip from the gun and hold a metal part of the gun firmly to the side of a grounded metal pail. |

4. **Prime the pump.**
 - a. Open the pressure drain valve (handle in downward position). If you did not install a secondary hose, be sure the nipple is tightly plugged with the cap provided. Turn the ON/OFF switch to ON. Slowly turn the pressure adjusting knob clockwise until the sprayer starts. When fluid comes from the drain hose, close the valve (handle in forward position).
 - b. Disengage the gun safety latch. See Fig. 3. Following the warning, above, trigger the gun until all air is forced out of the system and the paint flows freely from the gun.

- c. Release the trigger. Engage the gun safety latch.
5. **Check all fluid connections for leaks.** Relieve the fluid pressure before tightening connections.
 6. **Install the spray tip and tip guard.** Engage the gun safety latch. See Fig. 3. Install the spray tip according to the instructions supplied with it.
 7. **Adjust the spray pattern.**
 - a. Increase the pressure just until spray from the gun is completely atomized. Use the lowest pressure needed to get the desired results. This reduces overspray and fogging, decreases tip wear and extends the life of the sprayer.
 - b. If more coverage is needed, use a larger tip rather than increasing the pressure.
 - c. Test the spray pattern. To adjust the pattern, engage the gun safety latch, loosen the retaining nut. Position the tip guard horizontally for a horizontal pattern or vertically for a vertical pattern. Then tighten the retaining nut.

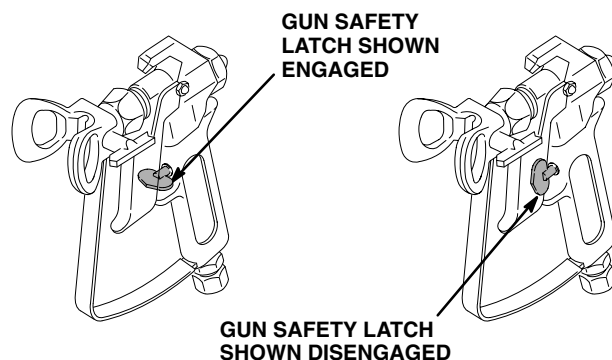

Fig. 3

0137

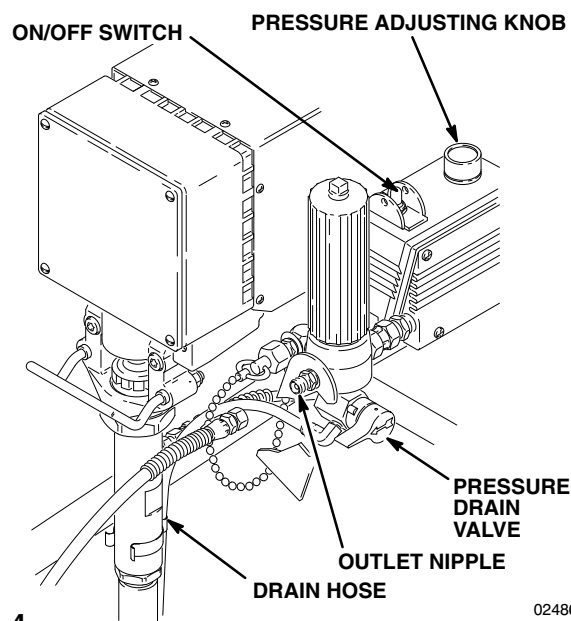

Fig. 4

02486

Startup

Cleaning a Clogged Tip

WARNING



FLUID INJECTION HAZARD

To reduce the risk of serious injury, follow the illustrated **Pressure Relief Procedure** warning on page 13 whenever you are instructed to relieve pressure.

1. Clean the front of the tip frequently during the day's operation. First, relieve pressure.
2. If the spray tip does clog, release the gun trigger, engage the gun safety latch, and rotate the RAC IV handle 180°. See Fig. 5.
3. Disengage the gun safety latch and trigger the gun into a waste container. Engage the gun safety latch again.

4. Return the handle to the original position, disengage the gun safety latch, and resume spraying.
5. If the tip is still clogged, engage the gun safety latch, shut off and unplug the sprayer, and open the pressure drain valve to relieve pressure. Clean the spray tip as shown in your spray gun manual.

**TIP GUARD HANDLE
SHOWN IN SPRAYING
POSITION**

**TURN HANDLE 180°,
DISENGAGE SAFETY
LATCH AND TRIGGER
GUN TO CLEAR CLOG**

**GUN SAFETY
LATCH
SHOWN
ENGAGED**

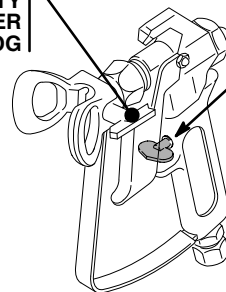



Fig. 5

0137

Shutdown and Care

| | |
|---|--|
| ⚠ WARNING | |
|  | FLUID INJECTION HAZARD To reduce the risk of serious injury, follow the illustrated Pressure Relief Procedure warning on page 13 whenever you are instructed to relieve pressure. |

1. **Check the packing nut/wet-cup daily.** First relieve pressure. Keep the wet-cup 1/3 full of TSL at all times to help prevent fluid buildup on the piston rod and premature wear of packings.

Tighten the packing nut just enough to stop leakage. Over tightening causes binding and excessive packing wear. Use a round punch or brass rod and light hammer to adjust the nut. Refer to Fig. 6.

2. **Clean the fluid filter often** and whenever the sprayer is stored. Follow the Flushing Guidelines on page 12 or refer to manual 307-273, supplied, for the cleaning procedure.
3. **Lubricate the bearing housing** after every 100 hours of operation. First relieve pressure. Remove the front cover. Fill the bearing housing cavity with SAE 10 non-detergent oil. See Fig. 7.
4. **For very short shutoff periods,** leave the suction tube in the paint, relieve pressure, and clean the spray tip.
5. **Flush the sprayer at the end of each work day** and fill it with mineral spirits to help prevent pump corrosion and freezing. See page 12.

| | |
|---|--|
| ⚠ CAUTION | |
| To prevent pump corrosion, never leave water or any type of paint in the sprayer when it is not in use. Pump water or paint out with mineral spirits. | |

6. **Coil the hose and hang it on the hose rack** when storing it, even for overnight, to help protect the hose from kinking, abrasion, coupling damage, etc.

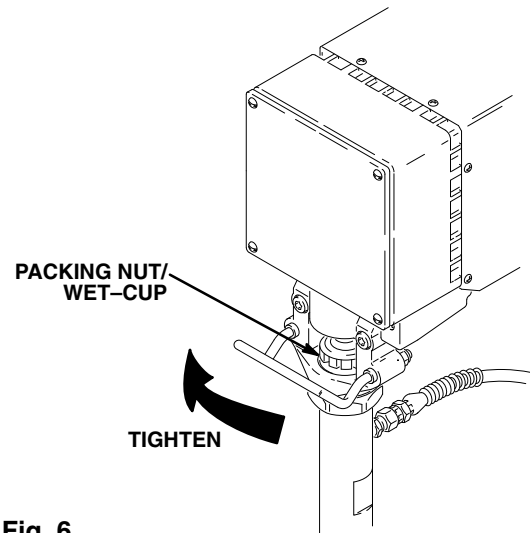

Fig. 6

04285

FILL BEARING HOUSING CAVITY WITH SAE NON-DETERGENT OIL AFTER EVERY 100 HOURS OF OPERATION

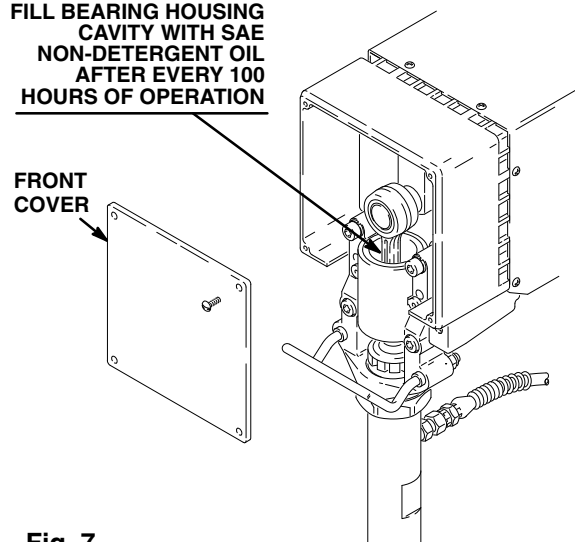

Fig. 7

04289

Flushing

NOTE: Several flushes are often required to thoroughly clean the system and prepare it for the next fluid to be sprayed, or to store the sprayer. Use this chart to determine the required flushing order for the fluid you are using, and then follow the procedure below for flushing.

*Use this category for flushing a brand new sprayer and flushing after storage.

| System has this fluid in it: | Next fluid to be sprayed. | Flushing order: | | | Before you spray or store sprayer: |
|------------------------------|-------------------------------|------------------|------------------|-----------------|--|
| | | Flush 1 | Flush 2 | Flush 3 | |
| *Oil-based solvent or paint | Oil-based paint – new color | Mineral spirits | none | none | Prime with oil-based paint |
| Oil-based solvent or paint | Water-based paint | Mineral spirits | Warm soapy water | Clean water | Prime with water-based paint |
| Oil-based solvent or paint | Prepare for storage | Mineral spirits | none | none | Relieve pressure, Leave drain valve open |
| Water or water-based paint | Water-based paint – new color | Warm soapy water | Clean water | none | Prime with water |
| Water or water-based paint | Oil-based paint | Warm soapy water | Clean water | Mineral spirits | Prime with oil |
| Water or water-based paint | Prepare for storage | Warm soapy water | Clean water | Mineral spirits | Relieve pressure, Leave drain valve open |

⚠ WARNING

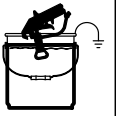

FIRE AND EXPLOSION HAZARD

To reduce the risk of static sparking and splashing when flushing, always remove the spray tip from the gun and hold a metal part of the gun firmly to the side of a grounded metal pail.

1. Follow the illustrated **Pressure Relief Procedure** on page 13. Engage the gun safety latch.
2. Turn the pressure adjusting knob fully counter-clockwise to zero pressure.
3. Remove the spray tip from the gun. Remove the filter bowl and screen; see manual 307–273. Clean the screen separately and install the bowl without the screen to flush it. See Fig. 8.
4. Put the suction tube into a grounded metal pail with 1/2 gallon of compatible solvent.
5. Start the sprayer. See page 9. To save the fluid still in the sprayer, trigger the gun into another container until the next fluid appears, then trigger the gun back into the fluid you are pumping. Circulate the flushing fluid a couple of minutes to thoroughly clean the system.

6. Do not run the pump dry for more than 30 seconds to avoid damaging the pump packings!
7. Follow the illustrated **Pressure Relief Procedure** on page 13. Engage the gun safety latch.
8. Unscrew the filter bowl and reinstall the clean screen. Install the bowl and hand tighten.
9. Remove the suction tube and screen and clean them separately.

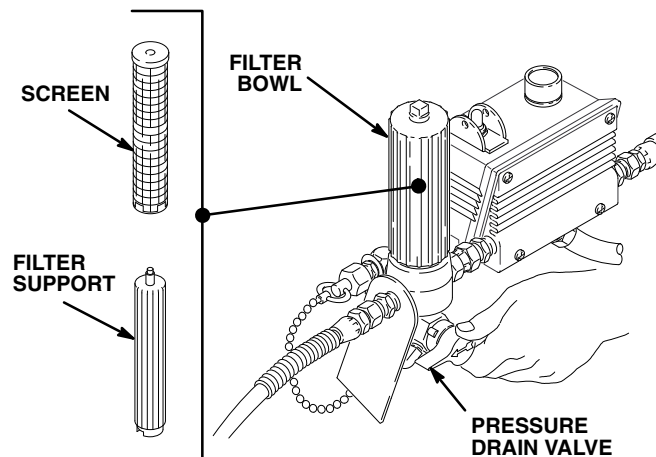

Fig. 8

04248

Troubleshooting

Pressure Relief Procedure

To reduce the risk of serious bodily injury, including fluid injection, splashing fluid or solvent in the eyes or on the skin, or injury from moving parts or electric shock, always follow this procedure whenever you shut off the sprayer, when checking or servicing any part of the spray system, when installing, cleaning or changing spray tips, and whenever you stop spraying.

1. Engage the gun safety latch.
2. Turn the ON/OFF switch to OFF.
3. Unplug the power supply cord.

4. Disengage the gun safety latch. Hold a metal part of the gun firmly to the side of a grounded metal pail, and trigger the gun to relieve pressure.
5. Engage the gun safety latch.
6. Open the pressure drain valve, having a container ready to catch the drainage. Leave the valve open until you are ready to spray again.

If you suspect that the spray tip or hose is completely clogged, or that pressure has not been fully relieved after following the steps above, VERY SLOWLY loosen the tip guard retaining nut or hose coupling to relieve pressure gradually, then loosen completely. Now clear the tip or hose.

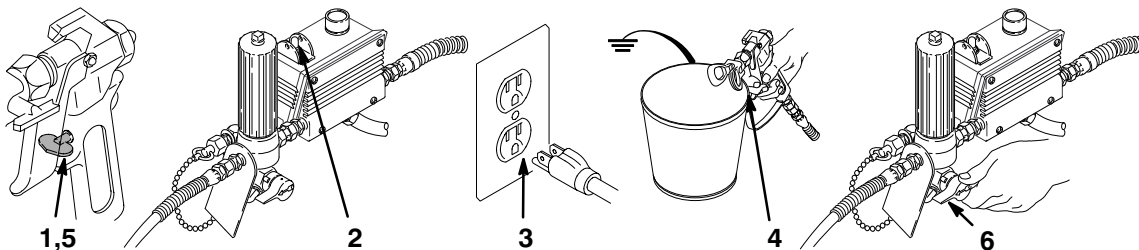

04240

Perform all **Troubleshooting** procedures before disassembling the sprayer.

MOTOR WON'T OPERATE

| TYPE OF PROBLEM | WHAT TO CHECK <i>If check is OK, go to next check</i> | WHAT TO DO <i>When check is not OK refer to this column</i> |
|-------------------------------|--|--|
| Basic Fluid Pressure Problems | 1. Check the pressure control knob setting. The motor will not run if it is at the minimum setting (fully counterclockwise). | 1. Slowly increase the pressure setting to see if the motor starts. |
| | 2. Check for a clogged spray tip or fluid filter. Refer to the separate gun, tip, or fluid filter instruction manual. | 2. Relieve pressure, refer to the separate gun, tip, or fluid filter instruction manual for cleaning. |
| Basic Mechanical Problems | 1. Check for frozen or hardened paint in the pump (71) and/or pressure control tube. Using a screwdriver, carefully try to rotate fan at back of motor by hand. See page 18. | 1. Thaw. Plug in sprayer and turn on. Slowly increase pressure setting to see if motor starts. If it doesn't, see NOTE 1, below. |
| | 2. Check displacement pump connecting rod pin (41). It must be completely pushed into connecting rod (63) and retaining spring (40) must be firmly in groove of connecting rod. See Fig. 32. | 2. Push pin into place and secure with spring retainer. |
| | 3. Check for motor damage. Remove drive housing assembly (77). See page 26. Try to rotate fan by hand. | 3. Replace motor (68) if fan won't turn. See page 28. |
| Basic Electrical Problems | 1. Check pressure control safety circuit. | 2. Turn pressure control ON/OFF switch to OFF to RESET. If the pressure control safety continues to trip, see ELECTRICAL SHORT on page 17. |
| | 2. Check electrical supply with volt meter. Meter should read 105–125 VAC. | 2. Reset building circuit breaker; replace building fuse. Try another outlet. |
| | 3. Check extension cord for damage. Check extension cord continuity with a volt meter. | 3. Replace extension cord. |
| | 4. Check sprayer power supply cord (314) for damage such as broken insulation or wires. | 4. Replace power supply cord. See page 21. |
| | 5. Check motor brush leads, terminals and brush length. Brush length should be 1/2" minimum. See page 20. | 5. Tighten terminal screws; replace brushes. See page 20. |

NOTE 1: Thaw the sprayer if water or water-based paint has frozen in it, due to exposure to low temperatures, by placing it in a warm area. Do not try to start the sprayer until it has thawed completely. If paint hardened (dried) in the sprayer, the pump packings and/or pressure control must be replaced. See page 30 (**Displacement Pump**) or 23 (**Pressure Control**).

MOTOR WON'T OPERATE (Continued)

| TYPE OF PROBLEM | WHAT TO CHECK <i>If check is OK, go to next check</i> | WHAT TO DO <i>When check is not OK refer to this column</i> |
|---|---|--|
| <p>Follow Pressure Relief Procedure on page 13. Remove gun from hose. Remove pressure control.</p> | <p>1. Check leads from motor to be sure they are securely fastened and properly mated.</p> | <p>1. Replace loose terminals; crimp to leads. Be sure male terminal blades are straight and firmly connected to mating part.</p> <p>Clean circuit board male terminals. Replace loose or damaged terminals. Securely reconnect leads.</p> |
| | <p>2. Check for loose motor brush lead connections and terminals. See page 20.</p> | <p>2. Tighten terminal screws. Replace brushes if leads are damaged. See page 20.</p> |
| | <p>3. Check brush length which should be 1/2" minimum. See page 20.</p> <p>NOTE: The brushes do not wear at the same rate on both sides of the motor. Check both brushes.</p> | <p>3. Replace brushes. See page 20.</p> |
| | <p>4. Check for broken or misaligned motor brush springs. Rolled portion of spring must rest squarely on top of brush. See page 20.</p> | <p>4. Replace spring if broken. Realign spring with brush. See page 20.</p> |
| | <p>5. Check motor brushes for binding in brush holders. See page 20.</p> | <p>5. Clean brush holders. Remove carbon with small cleaning brush. Align brush leads with slot in brush holder to assure free vertical brush movement.</p> |
| | <p>6. Check motor armature commutator for burn spots, gouges and extreme roughness. Remove motor cover and brush inspection plates to check. See page 20.</p> | <p>6. Remove motor and have motor shop resurface commutator if possible. See page 28.</p> |
| | <p>7. Check motor armature for shorts using armature tester (growler) or perform spin test. See page 18.</p> | <p>7. Replace motor. See page 28.</p> |
| | <p>8. Check pressure control board (301) by substituting with a good pressure control board. See page 23.</p> | <p>8. Replace with new pressure control board (301). See page 23.</p> |
| <p>Refer to the wiring diagram on page 38 to identify test points (TP).</p> | <p>1. Check power supply cord (314). Disconnect TP1 female (neutral) and TP2 female and connect volt meter to these leads. Plug in sprayer. Meter should read 105 to 125 VAC. Unplug sprayer. Reconnect TP2.</p> | <p>1. Replace power supply cord. See page 21.</p> |
| | <p>2. Check ON/OFF switch (307). Disconnect TP3 and connect volt meter to TP1 female and TP3 male terminal on the ON/OFF switch. Plug in sprayer and turn ON. Meter should read 105 to 125 VAC. Turn off and unplug sprayer. Reconnect TP3.</p> | <p>2. Replace ON/OFF switch. See page 22.</p> |
| | <p>3. Check motor terminal cutoff switch. Connect volt meter to TP1 female and TP4 female. Plug in sprayer and turn on. Meter should read 105 to 125 VAC. Turn off and unplug sprayer.</p> | <p>3. Allow motor to cool. Correct cause of overheating. If switch remains open after motor cools, check continuity between TP4 female and TP5 female with ohmmeter. If open, replace motor.</p> |
| | <p>4. Check all terminals for damage or loose fit. Reconnect TP1, TP4, and TP5 connectors.</p> | <p>4. Replace damaged terminals and reconnect securely.</p> |

LOW OUTPUT

| TYPE OF PROBLEM | WHAT TO CHECK <i>If check is OK, go to next check</i> | WHAT TO DO <i>When check is not OK refer to this column</i> |
|-----------------|--|--|
| Low Output | 1. Check for worn spray tip. | 1. Follow Pressure Relief Procedure Warning then replace tip. See your separate gun or tip manual. |
| | 2. Check to see that pump does not continue to stroke when gun trigger is released. Plug in and turn on sprayer. Prime with paint. Trigger gun momentarily, then release and engage safety latch. Relieve pressure, turn off and unplug sprayer. | 2. Service pump. See pages 30–33. |
| | 3. Check electrical supply with volt meter. Meter should read 105–125 VAC. | 3. Reset building circuit breaker; replace building fuse. Repair electrical outlet or try another outlet. |
| | 4. Check extension cord size and length; must be at least 12 gauge wire and no longer than 300 ft. | 4. Replace with a correct, grounded extension cord. |
| | 5. Check +, –, M+ and M– leads from motor to pressure control circuit board (B1) for damaged or loose wires or connectors. Inspect wiring insulation and terminals for signs of overheating. See page 28. | 5. Be sure male terminal blades are centered and firmly connected to female terminals. Replace any loose terminal or damaged wiring. Securely reconnect terminals. |
| | 6. Check for loose motor brush leads and terminals. See page 20. | 6. Tighten terminal screws. Replace brushes if leads are damaged. See page 20. |
| | 7. Check for worn motor brushes which should be 1/2" minimum. See page 20. | 7. Replace brushes. See page 20. |
| | 8. Check for broken and misaligned motor brush springs. Rolled portion of spring must rest squarely on top of brush. | 8. Replace spring if broken. Realign spring with brush. See page 20. |
| | 9. Check motor brushes for binding in brush holders. See page 20. | 9. Clean brush holders, remove carbon dust with small cleaning brush. Align brush lead with slot in brush holder to assure free vertical brush movement. |
| | 10. Check stall pressure. | 10. Replace with new pressure control board (301). See page 23. |
| | 11. Check pressure control board (301) by substituting with a good pressure control board. See page 23. | 11. Replace with new pressure control board (301). See page 23. |
| | 12. Check motor armature for shorts by using an armature tester (growler) or perform spin test. See page 18. | 12. Replace motor. See page 28. |

NO OUTPUT

| TYPE OF PROBLEM | WHAT TO CHECK <i>If check is OK, go to next check</i> | WHAT TO DO <i>When check is not OK refer to this column</i> |
|-------------------------------------|--|---|
| Motor runs and pump strokes | 1. Check paint supply. | 1. Refill and reprime pump. |
| | 2. Check for clogged intake strainer. | 2. Remove and clean, then reinstall. |
| | 3. Check for loose suction tube or fittings. | 3. Tighten; use thread sealant or sealing tape on threads if necessary. |
| | 4. Check to see if intake valve ball and piston ball are seating properly. See page 30. | 4. Remove intake valve and clean. Check balls and seats for nicks; replace if necessary. See page 30. Strain paint before using to remove particles that could clog the pump. |
| | 5. Check for leaking around throat packing nut which may indicate worn or damaged packings. See page 30. | 5. Replace packings. See pages 30–33. Also check piston valve seat for hardened paint or nicks and replace if necessary. Tighten the packing nut/wet-cup. |
| Motor runs but pump does not stroke | 1. Check displacement pump connecting rod pin (41). See page 32. | 1. Replace pin if missing. Be sure retainer spring (40) is fully in groove all around connecting rod. See page 32. |
| | 2. Check connecting rod assembly (63) for damage. See page 25. | 2. Replace connecting rod assembly . See page 25. |
| | 3. Be sure crank in drive housing rotates; plug in sprayer and turn on briefly to check. Turn off and unplug sprayer. See page 26. | 3. Check drive housing assembly for damage and replace if necessary. See page 26. |

EXCESSIVE PRESSURE FLUCTUATIONS

| TYPE OF PROBLEM | WHAT TO CHECK <i>If check is OK, go to next check</i> | WHAT TO DO <i>When check is not OK refer to this column</i> |
|---------------------------|---|---|
| Spray pattern variations. | 1. Be sure leads to pressure control circuit board (B1) are firmly connected. Be sure all male terminals blades are centered and firmly connected to female terminals. See Fig. 33. | 1. Reconnect securely. See Fig. 33. |
| | 2. Check maximum working pressure. | 2. Replace with a new pressure control board (301). See page 23. |
| | 3. Check pressure control board (301) by substituting with a good pressure control board. See page 23. | 3. Replace with a new pressure control board (301). See page 23. |
| | 4. Check LOW OUTPUT section, page 15. | |

MOTOR IS HOT AND RUNS INTERMITTENTLY

| TYPE OF PROBLEM | WHAT TO CHECK <i>If check is OK, go to next check</i> | WHAT TO DO <i>When check is not OK refer to this column</i> |
|---------------------------------------|--|--|
| Motor is hot and runs intermittently. | 1. Determine if sprayer was operated at high pressure with small tips, which causes low motor RPM and excessive heat build up. | 1. Decrease pressure setting or increase tip size. |
| | 2. Be sure ambient temperature where sprayer is located is no more than 90°F and sprayer is not located in direct sun. | 2. Move sprayer to shaded, cooler area if possible. |
| | 3. Determine if sprayer was turned on, pressurized, but not operating for long periods of time. | 3. Turn off sprayer whenever you stop spraying for a while and relieve fluid pressure. |

ELECTRICAL SHORT

| TYPE OF PROBLEM | WHAT TO CHECK <i>If check is OK, go to next check</i> | WHAT TO DO <i>When check is not OK refer to this column</i> |
|---|--|---|
| Building circuit breaker opens as soon as sprayer switch is turned on. CAUTION Any short in any part of the motor power circuit will cause the control circuit to inhibit sprayer operation. Correctly diagnose and repair all shorts before checking and replacing control board. | 1. Check all electrical wiring for damaged insulation, and all terminals for loose fit or damage. Also check wires between pressure control and motor which are encased in conduit (1). See page 28. | 1. Repair or replace any damaged wiring or terminals. Securely reconnect all wires. |
| | 2. Check for missing inspection plate gasket (see page 28), bent terminal forks or other metal to metal contact points which could cause a short. | 2. Correct faulty conditions. |
| | 3. Check motor armature for shorts. Use an armature tester (growler) or perform spin test. See page 18. Inspect windings for burns. | 3. Replace motor. See page 28. |
| | 4. Check pressure control board (301) by substituting with a good control board. See page 23. | 4. Replace with a new pressure control board (301). See page 23. |
| Building circuit breaker opens as soon as sprayer is plugged into outlet and sprayer is NOT turned on. | 1. Check Basic Electrical Problems on page 13. | 1. Perform necessary procedures. |
| | 2. Check ON/OFF switch (307) See page 22. <i>Be sure the sprayer is unplugged!</i> Disconnect wires from switch. Check switch with ohmmeter. The reading should be infinity with the ON/OFF switch OFF, and zero with the switch ON. | 2. Replace ON/OFF switch. See page 22. |
| | 3. Check for damaged or pinched wires in the pressure control. See page 23. | 3. Replace damaged parts. See page 23. |
| Sprayer quits after sprayer operates for 5 to 10 minutes. | 1. Check Basic Electrical Problems on page 13. | 1. Perform necessary procedures. |
| | 2. Check electrical supply with volt meter. Meter should read 105 to 125 VAC. | 2. If voltage is too high, do not operate sprayer until corrected. |
| | 3. Check tightness of pump packing nut. Overtightening tightens packings on rod, restricts pump action, and damages packings. | 3. Loosen packing nut. Check for leaking around throat. Replace pump packings, if necessary. See page 30. |

Spin Test

⚠ WARNING

ELECTRIC SHOCK HAZARD

Do not touch the brushes, leads, springs or brush holders while the sprayer is plugged in to reduce the risk of electric shock and serious bodily injury.

⚠ WARNING

INJECTION HAZARD

To reduce the risk of serious injury, follow the illustrated **Pressure Relief Procedure** warning on page 13 whenever you are instructed to relieve pressure.

For checking armature, motor winding and brush electrical continuity.

Setup

Relieve pressure. Remove the drive housing. See page 26.

Remove the motor shield (34), the fan cover (F) and the inspection covers (J). See Fig. 9.

Remove the pressure control/cover(301). Disconnect the – and + leads from the motor to the pressure control/cover terminals M–, and M+. See Fig. 10.

Armature Short Circuit Test

Relieve pressure. Quickly turn the motor fan by hand. If there are no shorts, the motor will coast two or three revolutions

before coming to a complete stop. If the motor does not spin freely, the armature is shorted and the motor must be replaced. See page 28.

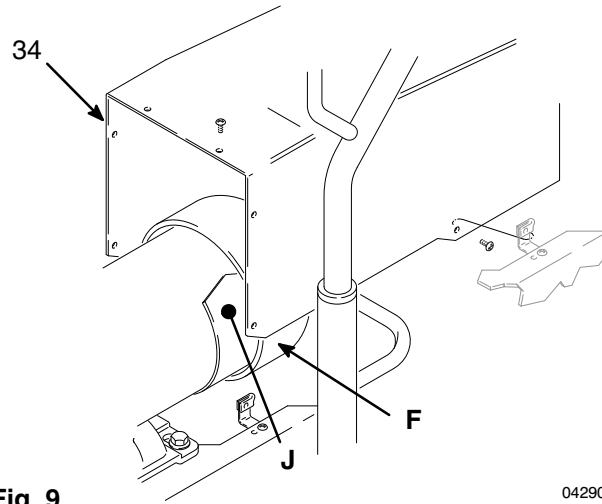

Fig. 9

04290

Armature, Brushes, and Motor Wiring Open Circuit Test (Continuity)

Relieve pressure. Connect the two black motor leads together with a test lead. Turn the motor fan by hand at about two revolutions per second.

If there is uneven or no turning resistance, check the following: broken brush springs, brush leads, motor leads; loose brush terminal screws, motor lead terminals; worn brushes. Repair parts as needed. See page 20.

If there is still uneven or no turning resistance, replace the motor. See page 28.

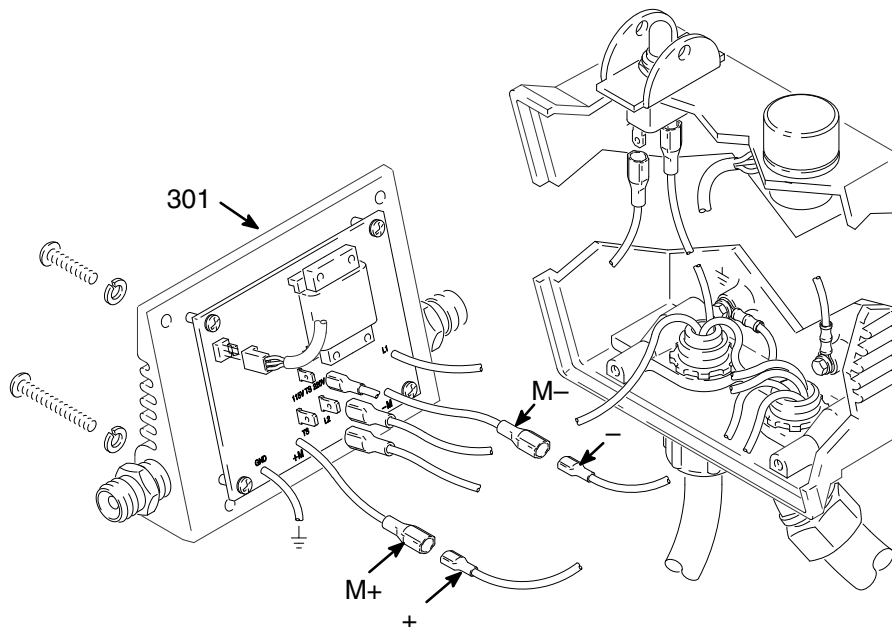

Fig. 10

04247

General Repair Information

CAUTION

To reduce the risk of a pressure control malfunction:

- Always use needle nose pliers to disconnect a wire. Never pull on the wire, pull on the connector.
- Mate wire connectors properly. Be sure the flat blade of the insulated male connector is centered in the wrap-around blade of the female connector.
- Route wires carefully to avoid interference with the other connections of the pressure control. Be sure the wires are not pinched between the cover and the control box.

Tool List

| | |
|------------------------------|-------------------------|
| Phillips screwdriver | 1/4 in. hex key wrench |
| Small flat blade screwdriver | 3/16 in. hex key wrench |
| Needle nose pliers | 5/8 in. socket wrench |
| Plastic mallet | 3/8 in. open end wrench |
| Adjustable wrench | 1/2 in. open end wrench |
| Adjustable, open-end wrench | 3/4 in. open end wrench |
| Torque wrench | 7/8 in. open end wrench |
| | High quality motor oil |
| | Bearing grease |

1. **Keep all screws, nuts, washers, gaskets, and electrical fittings** removed during repair procedures. These parts are not normally provided with replacement assemblies.
2. **Test your repair before regular operation** of the sprayer to be sure the problem is corrected.

WARNING



ELECTRIC SHOCK HAZARD

To reduce the risk of serious injury, including electric shock, **DO NOT** touch any moving parts or electrical parts with your fingers or a tool while inspecting the repair. Shut off the sprayer and unplug it as soon as you complete the inspection. Reinstall all covers, gaskets, screws and washers before operating the sprayer.

3. **If the sprayer does not operate properly**, review the repair procedure again to verify that everything was done correctly. If necessary, see the Troubleshooting Guide, pages 13 – 17, to help identify other possible problems and solutions.

CAUTION

Do not run the sprayer dry for more than 30 seconds to avoid damaging the pump packings.

4. **Reinstall the motor shield before regular operation** of the sprayer and replace it if it is damaged. The cover directs cooling air around the motor to help prevent overheating. It can also help reduce the risk of burns, fire or explosion; see the **WARNING**, below.

WARNING



FIRE AND EXPLOSION HAZARD

During operation, the motor and drive housing become very hot and could burn your skin if touched. Flammable materials spilled on the hot, bare motor could cause a fire or explosion. Always have the motor shield in place during regular operation to reduce the risk of burns, fire or explosion.

Motor Brush Replacement

NOTE: Replace the brushes when they have worn to less than 1/2 in. Note that the brushes wear differently on each side of the motor, so check them both. Brush Repair Kit 820-536 is available. A new spring clip, P/N 820-594 may be purchased separately.

⚠ WARNING

INJECTION HAZARD

To reduce the risk of serious injury, follow the illustrated **Pressure Relief Procedure** warning on page 13 whenever you are instructed to relieve pressure.

NOTE: Read the GENERAL REP AIR INFORMATION on page 19 before doing this procedure.

1. Relieve pressure.
2. Remove the motor shield (34). Remove the inspection covers and gaskets (J) on each side of the motor. See Fig. 11.

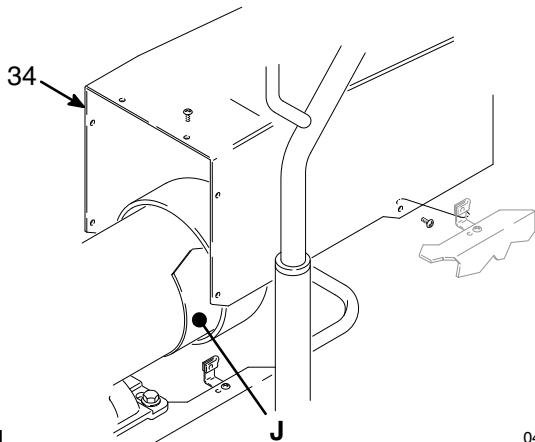

Fig. 11 04290

3. Push in the spring clip to release its hooks from the brush holder. Pull out the spring clip. See Fig. 12.

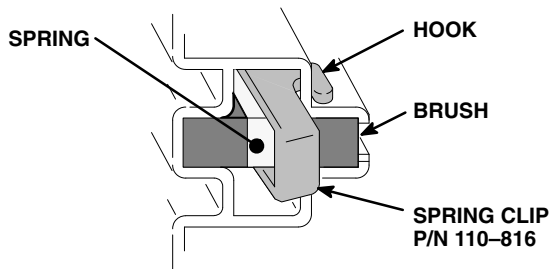

Fig. 12 01227

4. Loosen the brush lead terminal screw. Pull the brush lead away, leaving the motor lead terminal in place. Remove the brush and spring. See Fig. 14.

5. Inspect the commutator for excessive pitting, burning or gouging. A black color on the commutator is normal. Have the commutator resurfaced by a qualified motor repair shop if the brushes seem to wear too fast.

⚠ CAUTION

When installing the brushes, follow all steps carefully to avoid damaging the parts.

6. Install a new brush so the lead is in the long slot of the holder. See Fig. 13.

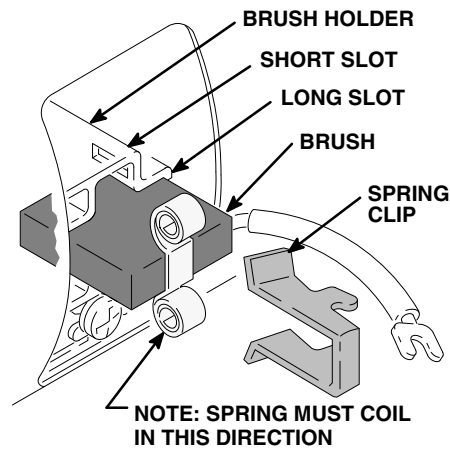

Fig. 13 01227

7. Slide the terminal under the terminal screw washer and tighten the screw. Be sure the motor lead is still connected at the screw. See Fig. 14.

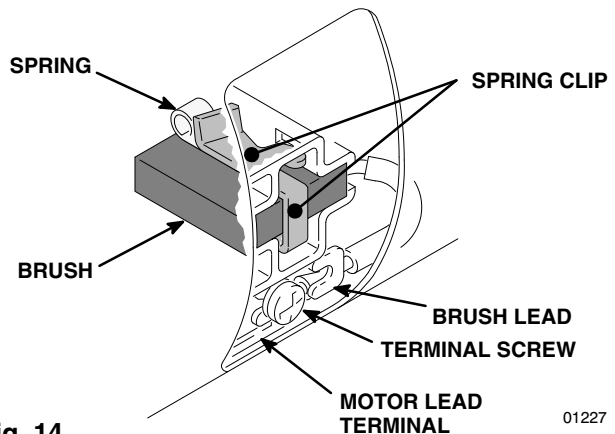



Fig. 14 01227

8. Place the spring on the brush as shown in Fig. 13.
9. Install the spring clip and push it down to hook the short slots in the housing. See Fig. 13.
10. Repeat for the other side.

11. Test the brushes.

- a. Remove the pump connecting rod pin.
- b. With the sprayer OFF, turn the pressure control knob fully counterclockwise to minimum pressure. Plug in the sprayer.
- c. Turn the sprayer ON. Slowly increase the pressure until the motor is at full speed.
- d. Inspect the brush and commutator contact area for excessive arcing. Arcs should not “trail” or circle around the commutator surface.

⚠ WARNING



ELECTRIC SHOCK HAZARD

Do not touch the brushes, leads, springs or brush holders while the sprayer is plugged in to reduce the risk of electric shock and serious bodily injury.

⚠ CAUTION

Do not run the sprayer dry for more than 30 seconds while checking the brushes to avoid damaging the displacement pump packings.

12. Install the brush inspection covers and gaskets.

13. **Break in the brushes.** Operate the sprayer for at least one hour with no load. Install the connecting rod pin.

Power Supply Cord Replacement (Fig. 15)

⚠ WARNING



INJECTION HAZARD

To reduce the risk of serious injury, follow the illustrated **Pressure Relief Procedure** warning on page 13 whenever you are instructed to relieve pressure.

NOTE: Read the GENERAL REP AIR INFORMATION on page 19 before doing this procedure.

1. Relieve pressure.
2. Remove the pressure control board/cover (301).
3. Disconnect the power supply cord (314) black lead from the ON/OFF switch (307), the white wire going to the circuit board (301), and the green wire to the grounding screw (317).
4. Loosen the strain relief bushing (315) and remove the power supply cord (314).
5. Install the new power supply cord in the reverse order.

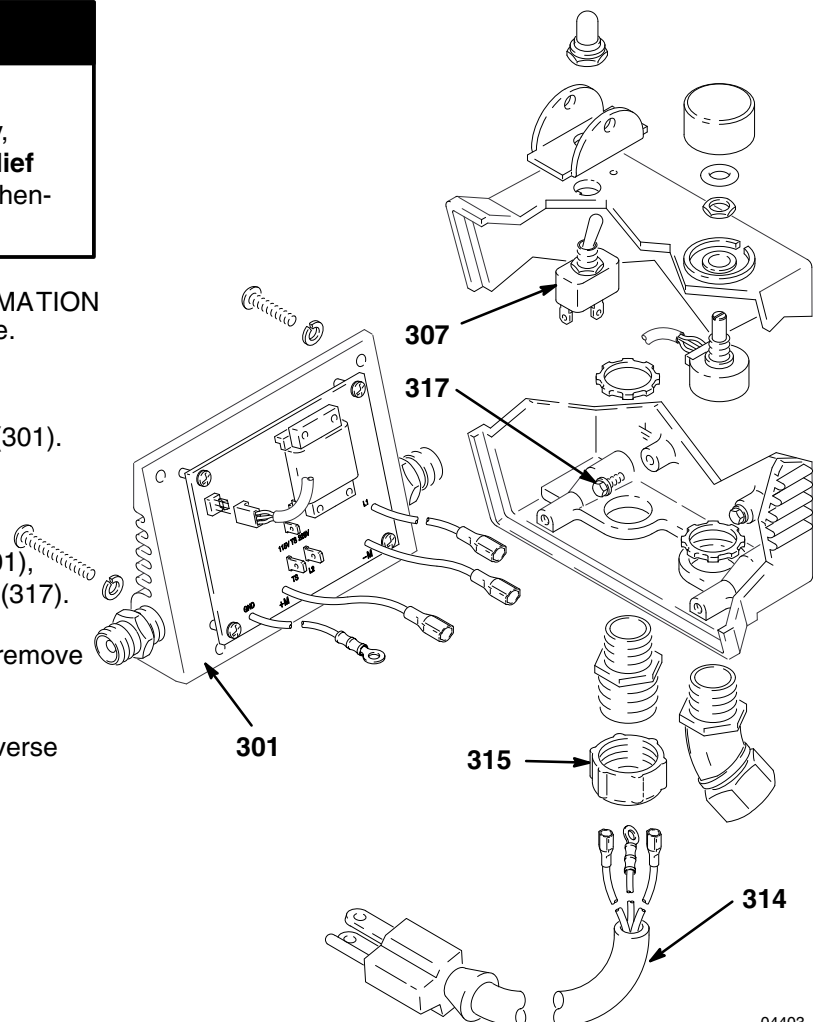

Fig. 15

04403

On/Off Switch Replacement (Fig. 16)

WARNING



FLUID INJECTION HAZARD

To reduce the risk of serious injury, follow the illustrated **Pressure Relief Procedure** warning on page 13 whenever you are instructed to relieve pressure.

NOTE: Read the GENERAL REP AIR INFORMATION on page 19 before doing this procedure.

1. Relieve pressure.
2. Remove the pressure control board/cover (301).
3. Disconnect the two wires from the ON/OFF switch (307). See Fig. 15.
4. Using a 5/8 in. socket wrench, remove the nut and rubber boot (309). Remove the switch guard (308). See Fig. 16.
5. Remove the ON/OFF switch (307).

6. Install the new switch so the internal tab of the pressure control housing (D) engages with the vertical groove in the threads of the switch.
7. Install the switch guard (308), aligning the internal tab with the groove in the threads.
8. Powder the inside of the rubber boot (309) with talcum powder, then shake the excess out of the boot.
9. Install the nut and rubber boot and tighten.
10. Reconnect all wires.

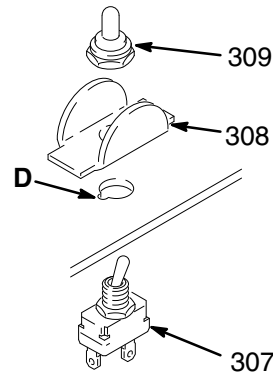



Fig. 16

01228

Pressure Control Replacement

| | |
|---|--|
| ⚠ WARNING | |
|  | FLUID INJECTION HAZARD To reduce the risk of serious injury, follow the illustrated Pressure Relief Procedure warning on page 13 whenever you are instructed to relieve pressure. |

1. Relieve pressure.
2. Disconnect the filter/drain valve assembly and the pump supply hose at the pressure control while holding the pressure control fitting (A) firmly. See the **CAUTION**, below. See Fig. 17.

| |
|---|
| ⚠ CAUTION |
| Do not allow the fittings (A) to turn when removing or connecting the hose and filter/drain assembly. Do not over tighten the screws when attaching the pressure control board/cover. Turning the fittings or over tightening the screws may shift the calibration of the pressure control. |

3. Remove the four mounting screws and washers (302, 303, 304) from the pressure control board/cover (301). See Fig. 18.
4. Carefully remove the pressure control board/cover (301) so as not to stress the cables.
5. Remove the potentiometer cable (310) from the pressure control board/cover (301).
6. Disconnect the pressure control board/cover black/white M+ and black M- leads from the motor + and- leads.
7. Disconnect the red motor leads from the TS terminals on the pressure control board/cover (301).
8. Disconnect the black power lead (L1) from the ON/OFF switch.
9. Disconnect the white power lead (L2) from the power cord (314) to the pressure control board/cover (301).
10. Loosen the ground terminal screw (317) and disconnect the ground lead (C).
11. Pull off the pressure control board/cover.

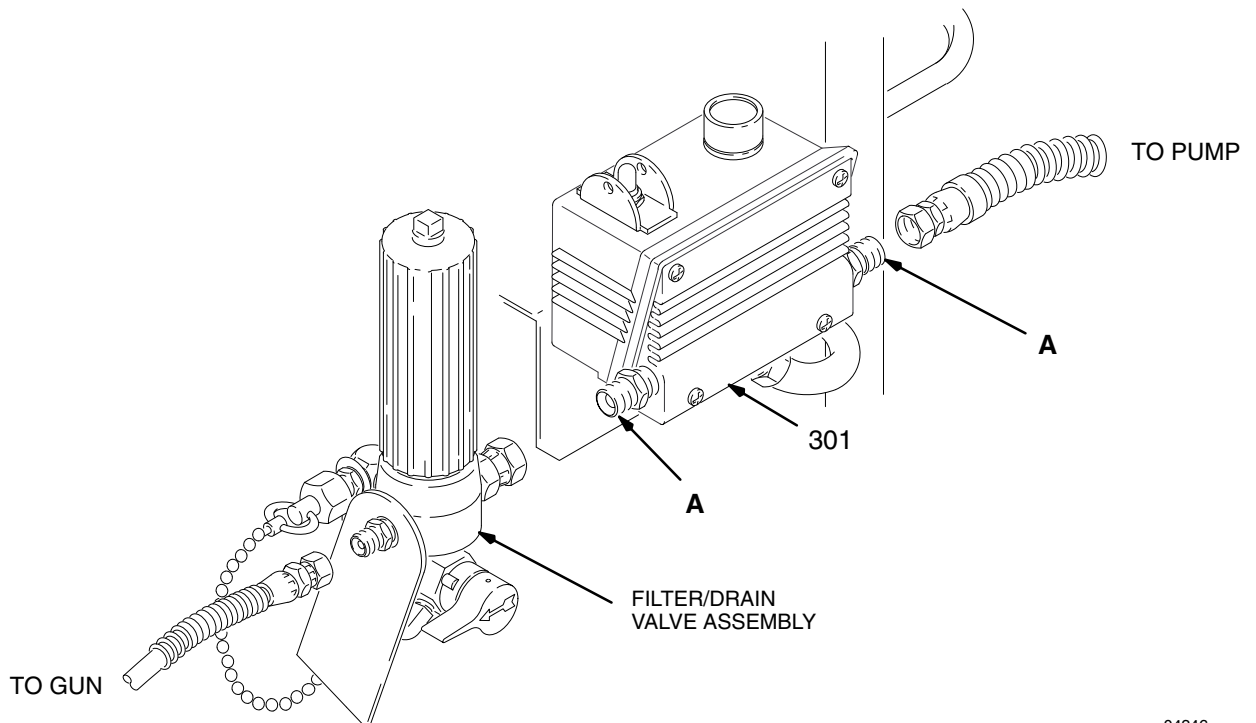

Fig. 17

04246

Pressure Control Replacement

⚠ WARNING

Do not attempt to adjust or calibrate the pressure control. If the pressure control is faulty, replace it.

12. Reassemble in the reverse order; attach ground wire (C), power leads (L1 and L2), the red leads to the TS terminals on the circuit board (B1), the M+ and M- leads, and the potentiometer cable to the connector on B1. Attach the pressure control board/cover (301) using the four mounting screws and washers (302, 303, 304),

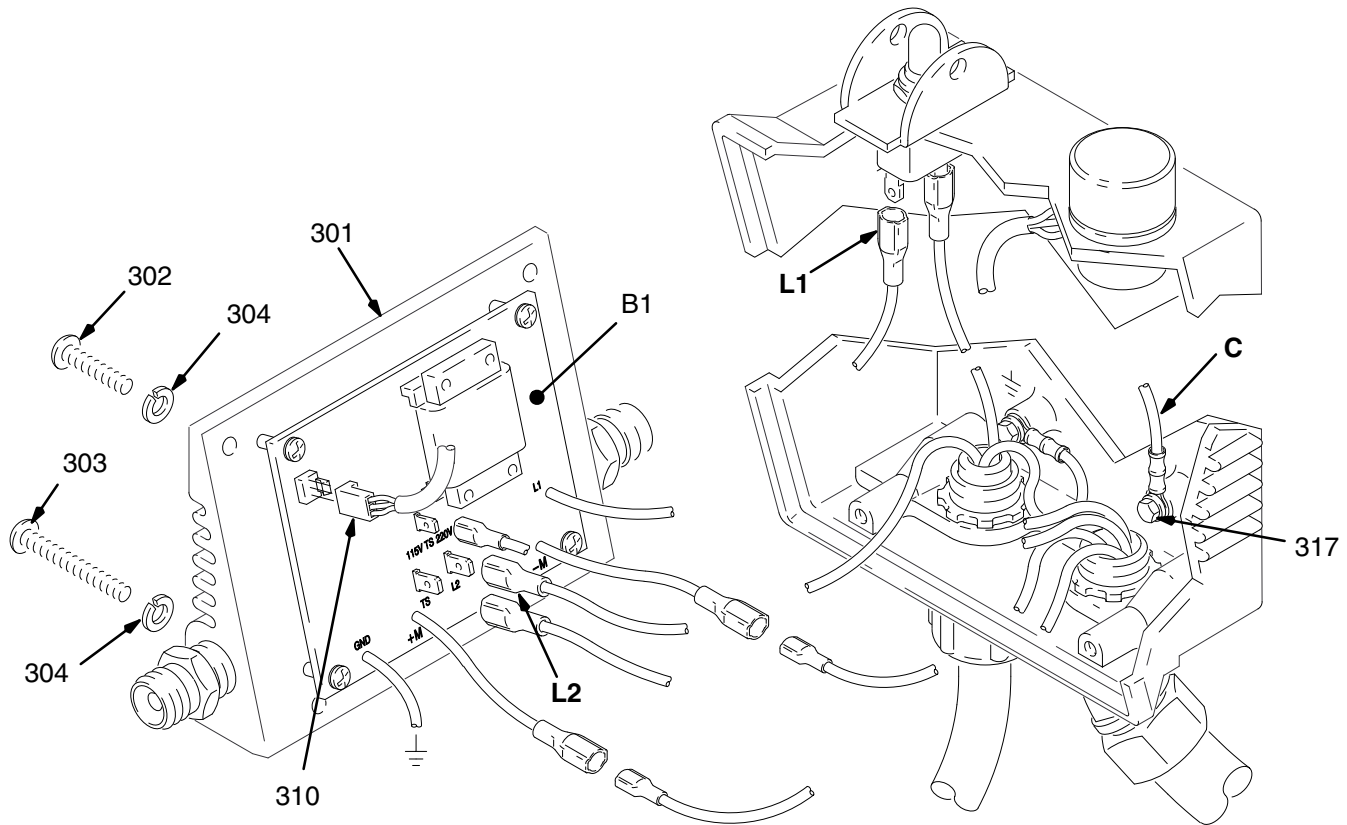

Fig. 18

04247

Bearing Housing and Connecting Rod Replacement (Fig. 19)

⚠ WARNING



FLUID INJECTION HAZARD

To reduce the risk of serious injury, follow the illustrated **Pressure Relief Procedure** warning on page 13 whenever you are instructed to relieve pressure.

NOTE: Read the GENERAL REP AIR INFORMATION on page 19 before doing this procedure.

NOTE: Stop the sprayer at the bottom of its stroke to get the crank (E) in its lowest position. To lower the crank manually, carefully rotate the blades of the fan with a screwdriver.

1. Relieve pressure.
2. Remove the front cover (76). Unclip the drain hose (14) from the pump. Hold a wrench on the pump intake valve (223) and unscrew the pump suction tube. Disconnect the pump hose (65).
3. Push up the retaining spring (40). Push the pin (41) out the rear.
4. Loosen the locknut (45). Unscrew the displacement pump (71).
5. Remove the four screws and lockwashers (37,23).
6. Lightly tap the lower rear of the bearing housing (64) with a plastic mallet to loosen it from the drive housing (77). Pull the bearing housing and the connecting rod assembly (63) straight off the drive housing.
7. Remove the pail bracket assembly (F) and install it on the new bearing housing.
8. Inspect the crank (E) for excessive wear and replace parts as needed. Evenly lubricate the inside of the bronze bearing (B) with high quality motor oil. Liberally pack the roller bearing (C) with bearing grease.
9. Assemble the connecting rod (63) and bearing housing (64).
10. Clean the mating surfaces of the bearing and drive housings (64,77).

11. Align the connecting rod (63) with the crank (E) and the drive housing locating pins (G) with the bearing housing (64) holes. Push the bearing housing onto the drive housing or tap it into place with a plastic mallet.

⚠ CAUTION

DO NOT use the bearing housing screws (37) to try to align or seat the bearing housing; the bearing and drive housing will not align properly and will result in premature bearing wear.

12. Install the screws and lockwashers (37,23). Tighten the screws evenly to 175 in-lb (19 N.m).
13. Install the pump. See page 32.
14. Install the remaining parts. See Fig. 19.

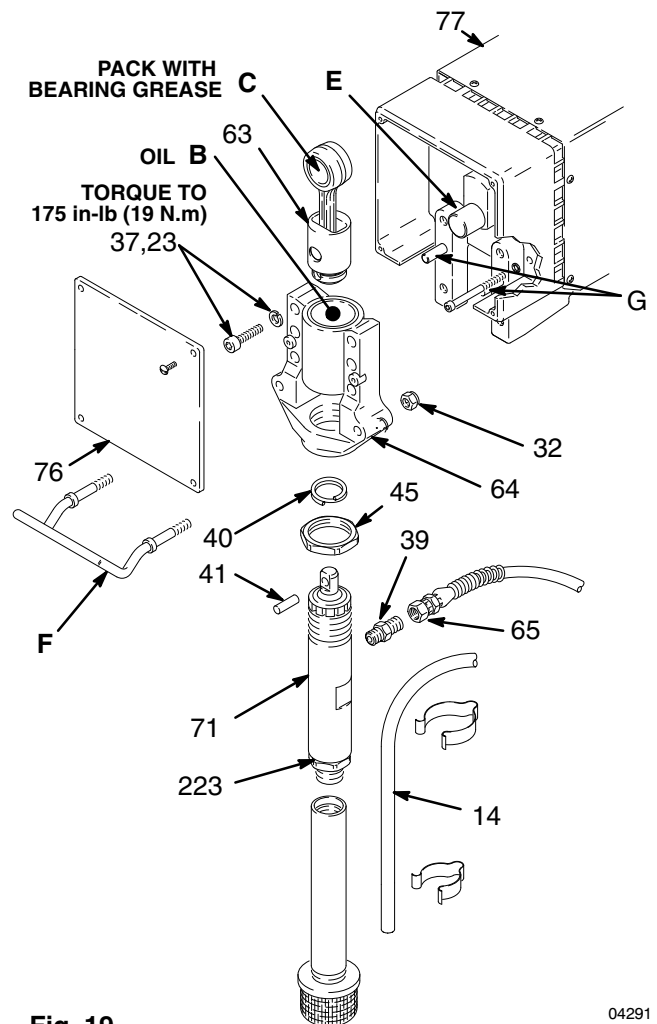

Fig. 19

04291

Drive Housing Replacement (Fig. 20)

WARNING



FLUID INJECTION HAZARD

To reduce the risk of serious injury, follow the illustrated **Pressure Relief Procedure** warning on page 13 whenever you are instructed to relieve pressure.

CAUTION

DO NOT drop the gear cluster (48) when removing the drive housing (77). The gear cluster may stay engaged in the motor front end bell or the drive housing.

DO NOT lose the thrust balls (8) located at each end of the gear cluster (48) or drop them between gears. The balls, which are heavily covered with grease, usually stay in the shaft recesses, but could be dislodged. If caught between gears and not removed, the balls will seriously damage the drive housing. If the balls are not in place, the bearings will wear prematurely.

NOTE: Read the GENERAL REP AIR INFORMATION on page 19 before doing this procedure.

1. Relieve pressure.
2. Remove the front cover (76) and the motor shield (34). Unclip the drain hose (14) from the pump.
3. Remove the four bearing housing screws (37) and lockwashers (23).
4. Lightly tap the lower rear of the bearing housing (64) with a plastic mallet to loosen it from the drive housing (77). Pull the assembled bearing housing and connecting rod straight off the drive housing.
5. Remove the two drive housing screws (26) and lockwashers (20).
6. Remove the two lower screws (12) and lockwashers (20) and then the two upper screws (13) and lockwashers (20) from the front of the motor (68).
7. Tap the drive housing (77) with a plastic mallet to loosen it from the front of the motor (68), and then pull the drive housing straight off.
8. Liberally apply bearing grease to the gear cluster (48). The gear area should have approximately 4 total ounces of grease. Grease is supplied with the drive housing replacement kit. Be sure the thrust balls (8) are in place.
9. Place the bronze-colored washer (77b) THEN the silver-colored washer (77a) on the shaft protruding from the big gear in the drive housing (77).
10. Align the gears and push the new drive housing straight onto the front of the motor and locating pins.
11. Continue reassembling the sprayer.

Drive Housing Replacement

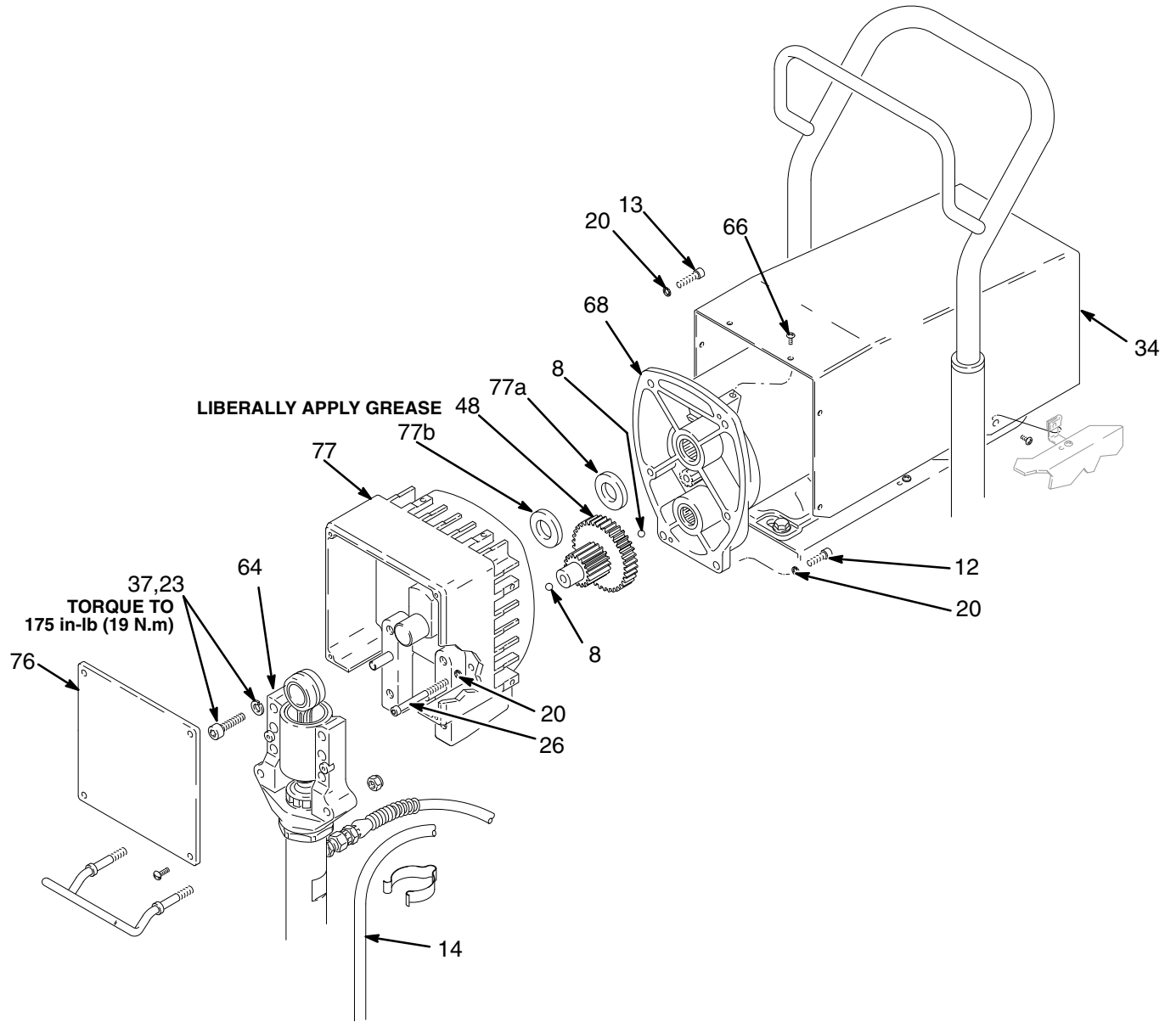

Fig. 20

04292

Motor Replacement (Fig. 21 and 22)

WARNING



FLUID INJECTION HAZARD

To reduce the risk of serious injury, follow the illustrated **Pressure Relief Procedure** warning on page 13 whenever you are instructed to relieve pressure.

NOTE: Read the GENERAL REP AIR INFORMATION on page 19 before doing this procedure.

1. Relieve pressure.
2. Remove the motor shield (34).
3. Remove the pressure control board/cover (301). Disconnect the four motor leads. See figure 21.
4. Loosen the conduit connector nut on the conduit connector (318) at the pressure control.
5. Swing the conduit (1) away from the conduit connector (318).
6. Remove the conduit seal (29) from around the conduit elbow coming into the pressure control. Pull the motor leads through the elbow, one at a time.

CAUTION

Always pull the motor leads one at a time to avoid loosening the terminals, which could result in a bad connection and poor sprayer performance.

7. Loosen the connector nut on the connector elbow (31) at the motor and pull the conduit (1) away from the motor. Pull the leads through the conduit, one at a time.
8. Unscrew the connector elbow (31) from the motor.
9. Pull the wires through the elbow, one at a time.
10. Remove the front cover (76).
11. Remove the two drive housing screws (26).

12. Remove the two lower screws (12) and lockwashers (20) and then the two upper screws (13) and lockwashers (20) from the front of the motor (68).
13. Tap the drive housing (77) with a plastic mallet to loosen it from the front of the motor (68), and then pull the drive housing straight off.

CAUTION

DO NOT drop the gear cluster (48) when removing the drive housing (77). The gear cluster may stay engaged in the motor front end bell or the drive housing.

DO NOT lose the thrust balls (8) located at each end of the gear cluster (48) or drop them between gears. The balls, which are heavily covered with grease, usually stay in the shaft recesses, but could be dislodged. If caught between gears and not removed, the balls will seriously damage the drive housing. If the balls are not in place, the bearings will wear prematurely.

14. While supporting the motor (68) to keep the sprayer from tipping, remove the four motor mounting screws (7). Lift off the motor.
15. Install the new motor (68).
16. Liberally apply bearing grease to the gear cluster (48). The gear area should have approximately 4 total ounces of grease. Grease is supplied with the drive housing replacement kit. Be sure the thrust balls (8) are in place.
17. Place the bronze-colored washer (77b) and then the silver-colored washer (77a) on the shaft protruding from the big gear in the drive housing (77).
18. Align the gears and push the drive housing (77) straight onto the front of the motor (68) and locating pins.
19. Continue reassembling the sprayer. Use a turning motion on the conduit (1) when feeding wires through it. Install the conduit seal (29) around the wires in the conduit elbow (318) at the pressure control to keep contaminants from entering the motor conduit. See the Detail in Fig. 22.

Motor Replacement

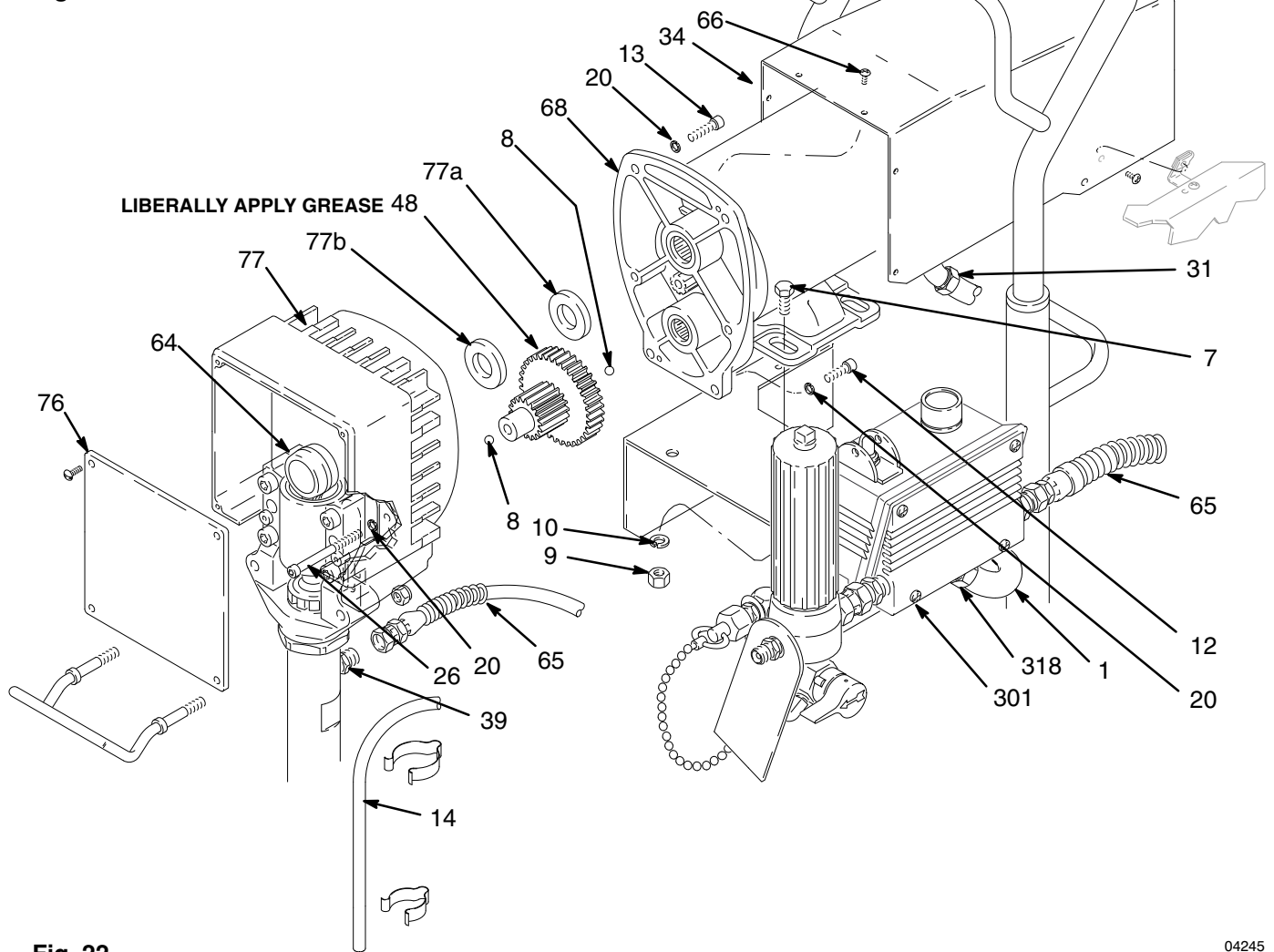
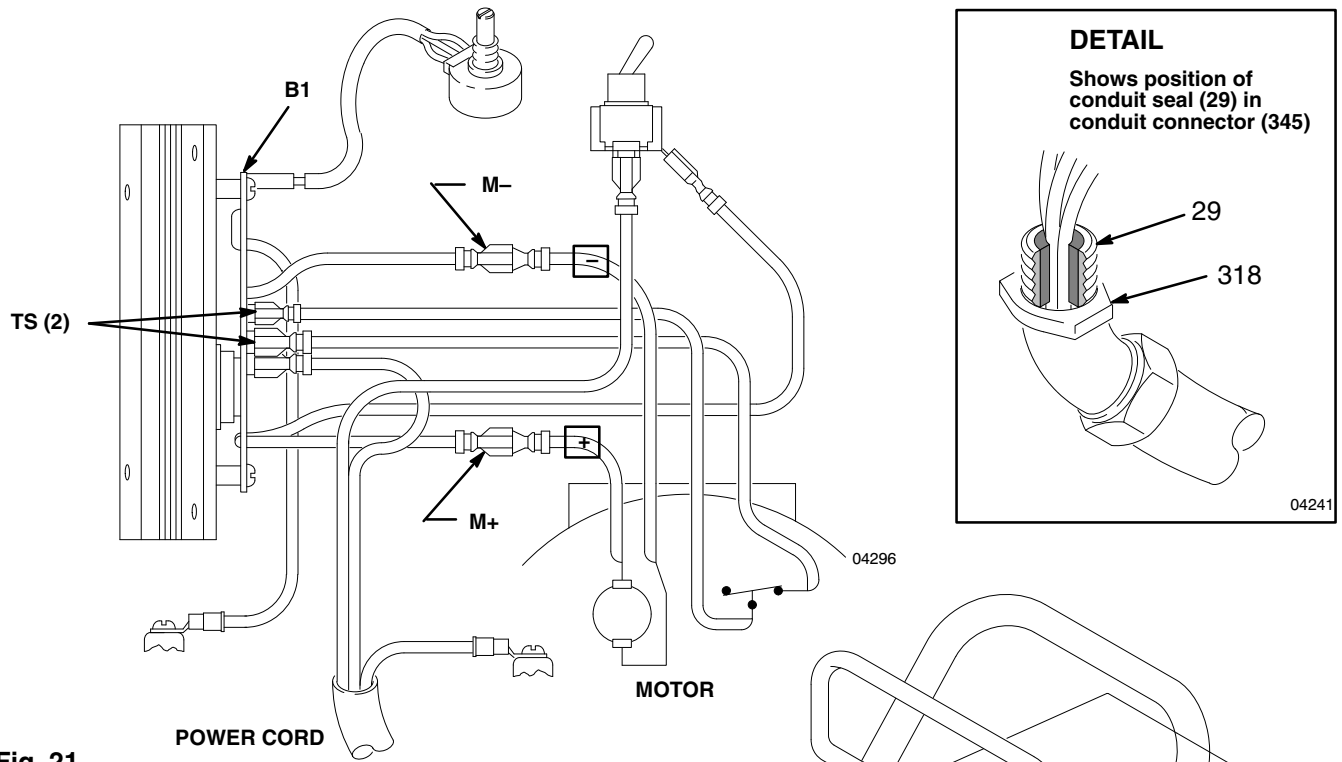

Displacement Pump Repair (Fig. 23, 24, 25 and 26)

⚠ WARNING



FLUID INJECTION HAZARD

To reduce the risk of serious injury, follow the illustrated **Pressure Relief Procedure** warning on page 13 whenever you are instructed to relieve pressure.

NOTE: Read the GENERAL REP AIR INFORMATION on page 19 before doing this procedure.

NOTE: Use Packing Repair Kit 820–520. An asterisk following a reference number, i.e., (210*), indicate that the part included in the kit. For the best results, use all the new parts in the kit even if the old ones still look good.

NOTE: Clean and inspect parts after disassembling the pump. Replace worn or damaged parts.

Disassembling the Pump

1. See page 32 to remove the pump.
2. Unscrew the intake valve (223) from the cylinder (219). Remove all parts. See Fig. 23.
3. If no further service is needed, reassemble the intake valve. Be sure you use a new o-ring (202*).
4. Remove the packing nut (216) and plug (205). See Fig. 23.
5. Use a plastic mallet to tap the piston rod (224) down, then pull the rod out through the bottom of the cylinder (219). See Fig. 23.
6. Remove the throat packings and glands. See Fig. 24.
7. Clamp the flats of the piston rod in a vise. Loosen the retaining nut (211). Unscrew the piston valve (222) from the rod. Remove all parts from the piston valve (222). See Fig. 25.
8. Remove and clean the sleeve (218). Use ONLY the special sleeve removal tool, P/N 820–576.

9. Screw the large nut (B) of the tool into the top of the cylinder (219). Screw down the rod (A) to push the sleeve out. Remove the tool. See Fig. 26.

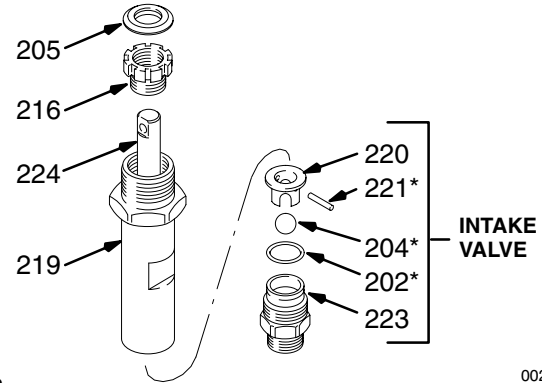

Fig. 23

0028

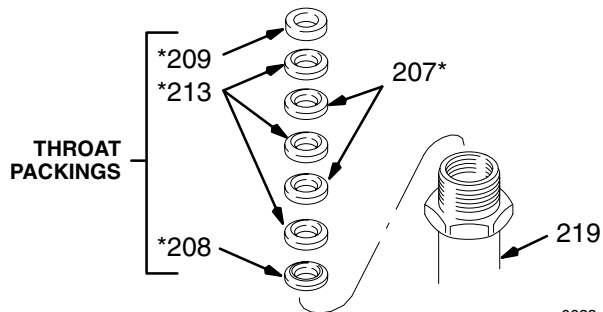

Fig. 24

0028

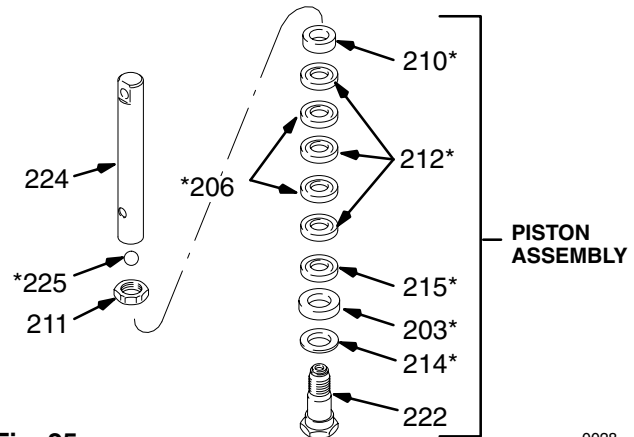

Fig. 25

0028

⚠ WARNING

Always use the special sleeve removal tool to remove the sleeve. Other removal methods could cause the pump to rupture, resulting in serious bodily injury. If the sleeve cannot be removed easily using the tool, return the sleeve and cylinder to your distributor for removal.

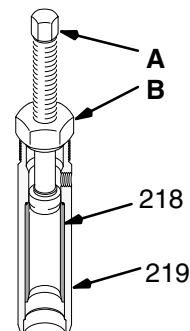

Fig. 26

0028

Displacement Pump Repair

Reassembling the Pump

NOTE: Alternate leather and plastic packings as shown in Fig. 27. The lips of the throat “V” packings must face down. The lips of the piston “V” packings must face up. The lips of the U-cup seal (203*) face down. Incorrect installation damages the packings and results in pump leaking.

NOTE: Soak leather packings in oil before using them.

1. Check the outside of the piston rod (224) and the inside of the sleeve (218) for scoring or scratches. If these parts are damaged, new packings will not seal properly. Replace these parts if needed.
2. Stack the backup washer (214), seal (203*), female gland (215*), alternate packings (212*,206*), and then male gland (210*) onto the piston valve (222). See Fig. 25.

3. Tighten the packing retaining nut (211) against the piston valve (222) to 10.5 in-lb (1.24 N.m).

Note the alignment of the piston (222) to the packing retainer nut (211). Maintain this alignment through Steps 5, 6 and 7.

4. Place the ball (225) on the piston valve (222). See Fig. 27.

| |
|---|
|  CAUTION |
| <p>Step 5 is critical. Follow the procedure carefully to avoid damaging the packings by overtightening.</p> |

5. Apply one drop of adhesive, supplied, to the piston valve threads. Then hand tighten the valve assembly into the piston rod just until the nut (211) contacts the rod. See Fig. 27.

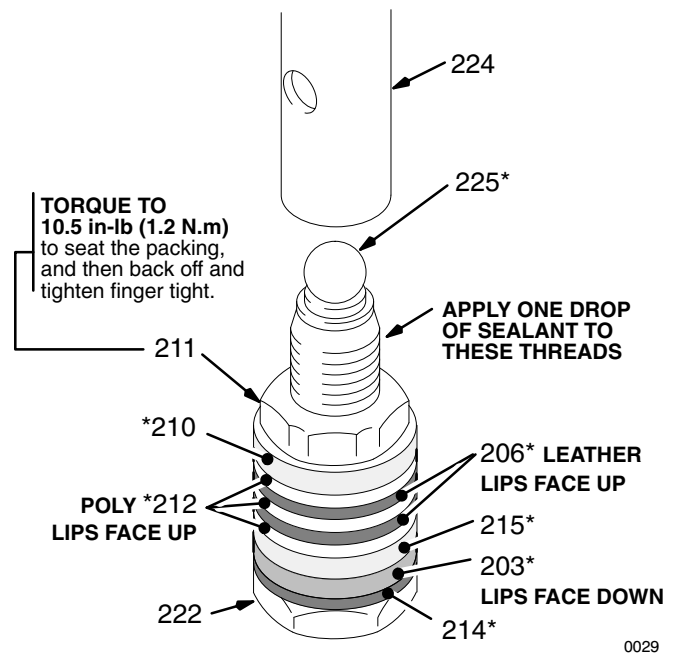

Fig. 27

6. Place the flats at the top of the rod in a vise.
7. Use a wrench to **CAREFULLY** tighten the nut (211) onto the piston rod to 19 ft-lbs (25 N.m). See Fig. 28.

Use two wrenches to maintain the alignment mentioned in Step 7, above.

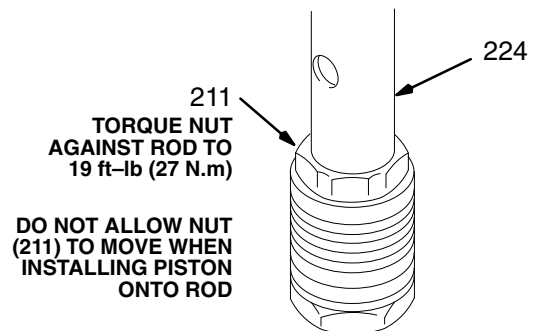

Fig. 28

8. Stack the male gland (208*), alternate packings (213*,207*), and female gland (9) into the top of the cylinder (219). See Fig. 29.
9. Install the packing nut (216) and plug (205), but leave loose for now. See Fig. 29.

Displacement Pump Repair

- Coat the piston rod and packings with oil. Carefully slide the assembly **INTO THE TOP OF THE SLEEVE**.

NOTE: The tapered end of the sleeve is the bottom of it. See Fig. 30.

- Place a new o-ring (202*) firmly in the cylinder groove. See Fig. 29

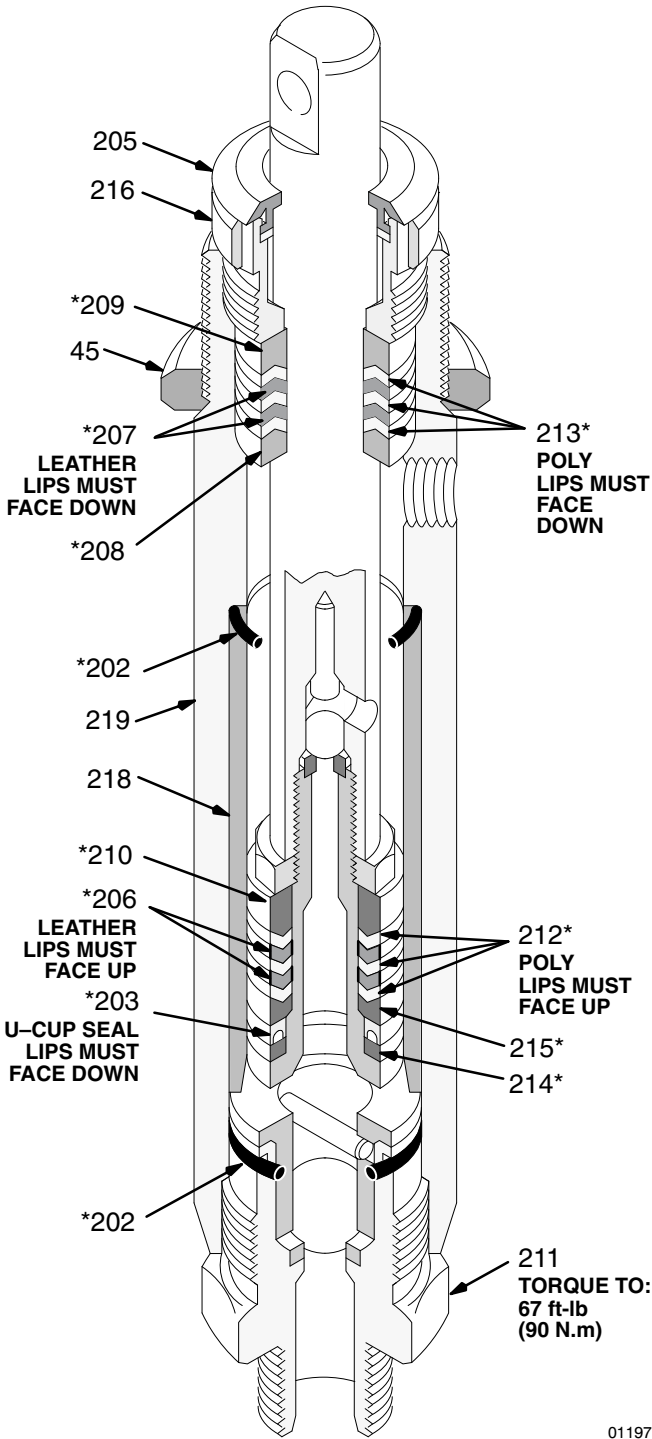

Fig. 29

01197

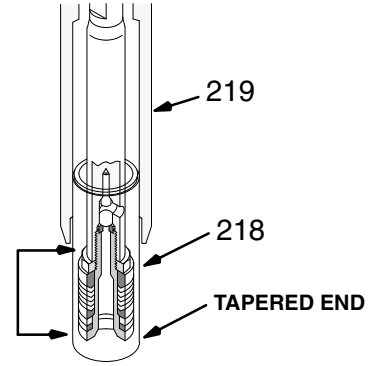

Fig. 30

0030

- Slide the sleeve/piston rod assembly **INTO THE BOTTOM OF THE CYLINDER**. This is to prevent packing damage during reassembly. See Fig. 30.
- Screw down the cylinder locknut (45) until it is finger tight at the bottom of the external cylinder threads.
- Place the flats of the intake valve (223) in a vise. Install a new o-ring (202*). Screw the pump cylinder into the valve. Torque to 67 ft-lb (90 N.m). See Fig. 29.
- Install the pump.

Displacement Pump Repair

REMOVING AND INSTALLING PUMP

Remove the pump (Fig. 31).

1. Flush the pump. Relieve pressure. Stop the pump with the piston rod (224) in its lowest position or carefully rotate the blades of the fan with a screwdriver to lower the rod.
2. While holding the pump intake valve (223) steady with a wrench, unscrew the suction tube (61).
3. Disconnect the hose (65).
4. Push the retaining spring (40) up. Push out the pin (41).
5. Loosen the locknut (45) and unscrew the pump from the bearing housing (64).

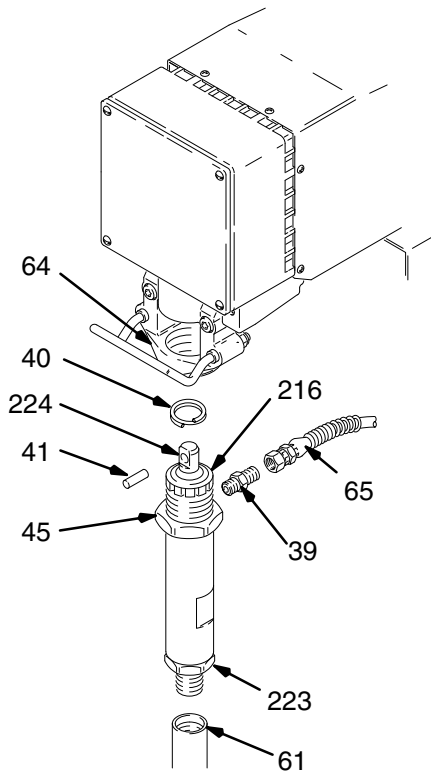

Fig. 31

04294

Install the pump (Fig. 32).

1. Screw the displacement pump 3/4 of the way into the bearing housing (64).
2. Hold the pin (41) up to the pin hole in the connecting rod assembly (63) and continue screwing in the pump until the pin slides easily into the hole. Back off the pump until the top threads of the pump cylinder are flush with the face of the bearing housing and the outlet nipple (39) is straight back.

3. Push the retaining spring (40) into the groove all the way around the connecting rod.
4. Tighten the locknut (45) very tight—about 70 ft-lb (97 N.m)—with a 2 in. open-end wrench and a light hammer.

⚠ WARNING

Be sure the retaining spring (40) is firmly in the groove of the connecting rod, all the way around, to prevent it from working loose due to vibration. Refer to Fig. 32.

If the pin works loose, parts could break off due to the force of the pumping action. These parts could be projected through the air and result in serious bodily injury, sprayer damage or property damage.

⚠ CAUTION

If the locknut (45) loosens during operation, the threads of the bearing housing (64) will be damaged. Be sure to tighten the locknut firmly.

5. Tighten the packing nut (216) just enough to stop leakage, but no tighter. Fill the wet-cup/packing nut 1/3 full with TSL (62).

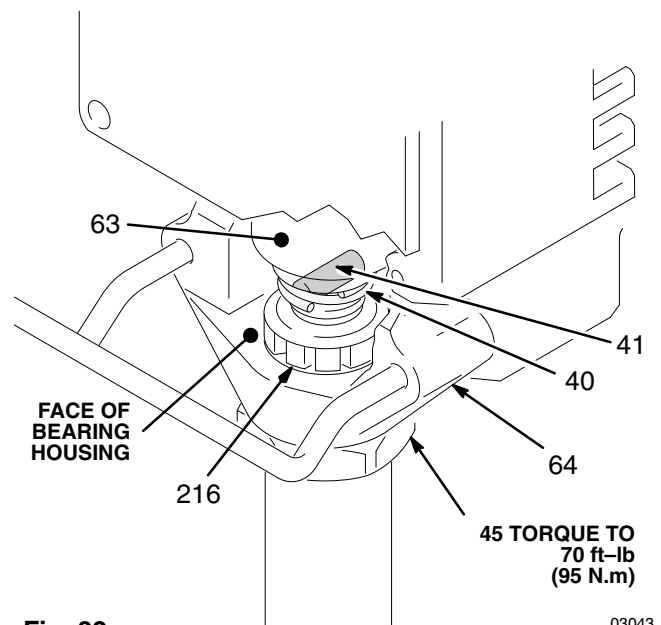
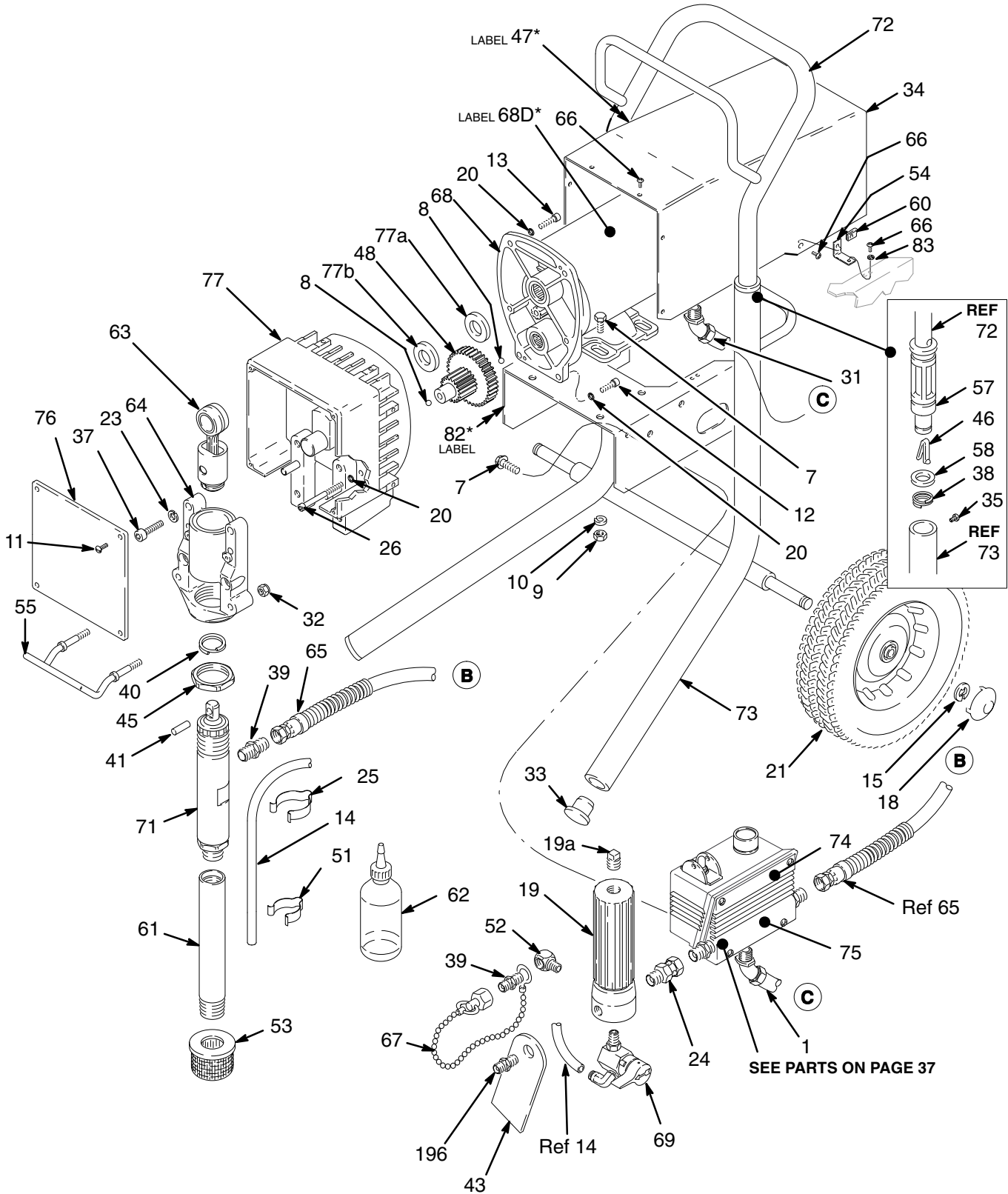

Fig. 32

03043

Parts Drawing – Sprayer

ULTIMATE *Plus*+1000 Sprayer
Model 820-210, Series A



Parts List – Sprayer

ULTIMATE Plus+1000 Sprayer

Model 820–210, Series A

Includes items 1 – 83

| REF NO. | PART NO. | DESCRIPTION | QTY | REF NO. | PART NO. | DESCRIPTION | QTY |
|---------|----------|--|--------|---------|-----------|--|-----|
| 1 | 821–039 | CONDUIT, electrical <i>specify length when ordering</i> | 0.7 ft | 52 | 820–410 | ADAPTER, elbow, 1/4–18 npt(mxf) | 1 |
| 7 | 820–675 | SCREW, serrated flange, hex hd, 5/16–18 x 3/4" | 7 | 53 | 820–950 | STRAINER | 1 |
| 8 | 820–457 | BALL, steel, 1/4" dia. | 2 | 54 | 820–588 | BRACKET | 2 |
| 9 | 820–267 | NUT, heavy hex, 5/16–18 unc–2a | 4 | 55 | 821–017 | HANGER, pail | 1 |
| 10 | 820–258 | LOCKWASHER, spring, 5/16" | 4 | 57 | 820–955 | SLEEVE | 2 |
| 11 | 820–307 | SCREW, filh, no. 8–32 x 1/2" | 4 | 58 | 820–564 | WASHER | 2 |
| 12 | 820–500 | SCREW, socket head, 1/4–20 x 1" | 2 | 60 | 820–587 | SPEED NUT | 2 |
| 13 | 820–316 | SCREW, socket head, 1/4–20 x 0.75" | 2 | 61 | 820–566 | TUBE, suction | 1 |
| 14 | 821–040 | HOSE, drain | 1 | 62 | 820–619 | THROAT SEAL LIQUID, 8 OZ | 1 |
| 15 | 820–469 | RING, retaining | 2 | 63 | 820–496 | CONNECTING ROD | 1 |
| 18 | 820–263 | HUBCAP | 2 | 64 | 820–499 | BEARING HOUSING | 1 |
| 19 | 820–586 | FLUID FILTER <i>includes items 19a and 19b see manual 307–273 for parts</i> | 2 | 65 | 820–524 | HOSE, grounded, nylon 1/4" ID, cpld 1/4 npsm(f), 29" (715 mm), spring guards both ends | 1 |
| 19a | 820–676 | • PLUG | 1 | 66 | 820–590 | SCREW, panhead, no. 8 x 3/8" | 10 |
| 19b | 820–421 | • NIPPLE, 1/4 npt(m) x 1/4 npsm | 1 | 67 | 820–498 | CAP, for secondary outlet | 1 |
| 20 | 820–273 | LOCKWASHER, spring, 1/4" | 6 | 68 | 820–493** | MOTOR, electric <i>includes items 68a through 68d, (shown on page 38) and one of item 8</i> | |
| 21 | 820–333 | WHEEL, semi–pneumatic | 2 | 68a | 820–441 | • TERMINAL, wire, female, snap-on | 2 |
| 23 | 820–315 | LOCKWASHER, spring, 3/8" | 4 | 68b | 820–447 | • TERMINAL, wire, female, snap-on | 1 |
| 24 | 820–041 | ADAPTER, female, ORS 3/8–18 npt(f) 11/16–16 UN thread | 1 | 68c | 820–429 | • TERMINAL, wire, female, snap-on | 1 |
| 25 | 820–606 | CLIP, large | 1 | 68d | 185–951* | • LABEL, DANGER, English | 1 |
| 26 | 820–506 | CAPSCREW, sch, 1/4–20 x 2.75" | 2 | 69 | 821–042 | VALVE, drain, pressure | 1 |
| 29 | 820–491 | SEAL, conduit, <i>see page 29</i> | 2 | 71 | 820–553 | DISPLACEMENT PUMP <i>see page 36 for parts</i> | 1 |
| 31 | 820–507 | CONNECTOR, conduit, 45° | 1 | 72 | 820–567 | HANDLE, cart | 1 |
| 32 | 821–016 | NUT, hex | 2 | 73 | 820–568 | FRAME, sprayer | 1 |
| 33 | 820–558 | PLUG, tubing | 2 | 74 | 820–218 | LABEL, ID, control, top | 1 |
| 34 | 820–101 | SHIELD, motor | 1 | 75 | 820–219 | LABEL, ID, control, bottom | 1 |
| 35 | 820–559 | SCREW, pnhd, 10–32 x 1/4" | 4 | 76 | 820–217 | COVER, housing, with label | 1 |
| 37 | 820–561 | CAPSCREW, sch, 3/8–16 unc–3a x 1 1/2" | 4 | 77 | 820–371 | DRIVE HOUSING <i>includes replaceable items 77a and 77b</i> | 1 |
| 38 | 820–562 | RING, retaining | 2 | 77a | 820–514 | • WASHER, silver-covered | 1 |
| 39 | 820–421 | NIPPLE, 1/4 npt(m) x 1/4 npsm | 3 | 77b | 820–515 | • WASHER, bronze-covered | 1 |
| 40 | 820–304 | SPRING, retaining | 1 | 82 | 185–955* | LABEL, DANGER (French) | 1 |
| 41 | 820–306 | PIN, straight, hds, 0.3125" dia x 1.023" | 1 | 83 | 820–589 | WASHER | 2 |
| 43 | 820–319* | TAG, WARNING | 1 | | | | |
| 45 | 820–353 | NUT, hex | 1 | | | | |
| 46 | 820–953 | BUTTON, snap | 2 | | | | |
| 47 | 185–953* | LABEL, DANGER – (English) | 1 | | | | |
| 48 | 820–495 | GEAR REDUCER | 1 | | | | |
| 51 | 820–488 | CLIP, small | 1 | | | | |

*Extra Danger and Warning tags and labels available free.

**Motor Brush Repair Kit 820–536 is available.
Order separately.

Parts Drawing & List – Displacement Pump

Model 820–553, Series A

Sleeved Displacement Pump

Includes items 202 to 225

| REF NO. | PART NO. | DESCRIPTION | QTY |
|---------|----------|---------------------------|-----|
| 202 | 820–617* | PACKING, o-ring, PTFE ® | 2 |
| 203 | 820–381* | SEAL, u-cup, polyurethane | 1 |
| 204 | 820–277* | BALL; sst | 1 |
| 205 | 820–395 | PLUG 1 | 1 |
| 206 | 820–383* | V-PACKING, leather | 2 |
| 207 | 820–384* | V-PACKING, leather | 2 |
| 208 | 820–385* | GLAND, male | 1 |
| 209 | 820–386* | GLAND, female | 1 |
| 210 | 820–387* | GLAND, male | 1 |
| 211 | 820–388 | NUT, hex, retaining | 1 |
| 212 | 820–390* | V-PACKING, polyethylene | 3 |
| 213 | 820–391* | V-PACKING, polyethylene | 3 |
| 214 | 820–392* | WASHER, backup | 1 |
| 215 | 820–393* | GLAND, female | 1 |
| 216 | 820–394 | NUT, packing | 1 |
| 218 | 820–571 | SLEEVE, cylinder | 1 |
| 219 | 820–572 | CYLINDER | 1 |
| 220 | 820–573 | GUIDE, ball | 1 |
| 221 | 820–382* | PIN, ball stop | 1 |
| 222 | 820–360 | VALVE, piston | 1 |
| 223 | 820–574 | VALVE, intake | 1 |
| 224 | 820–575 | ROD, piston | 1 |
| 225 | 820–276* | BALL; sst | 1 |

***Supplied in Repair Kit 820–520.**

Must be purchased separately.

Sleeve Removal Tool 820–576

Required for removing a pump sleeve.

Must be purchased separately.

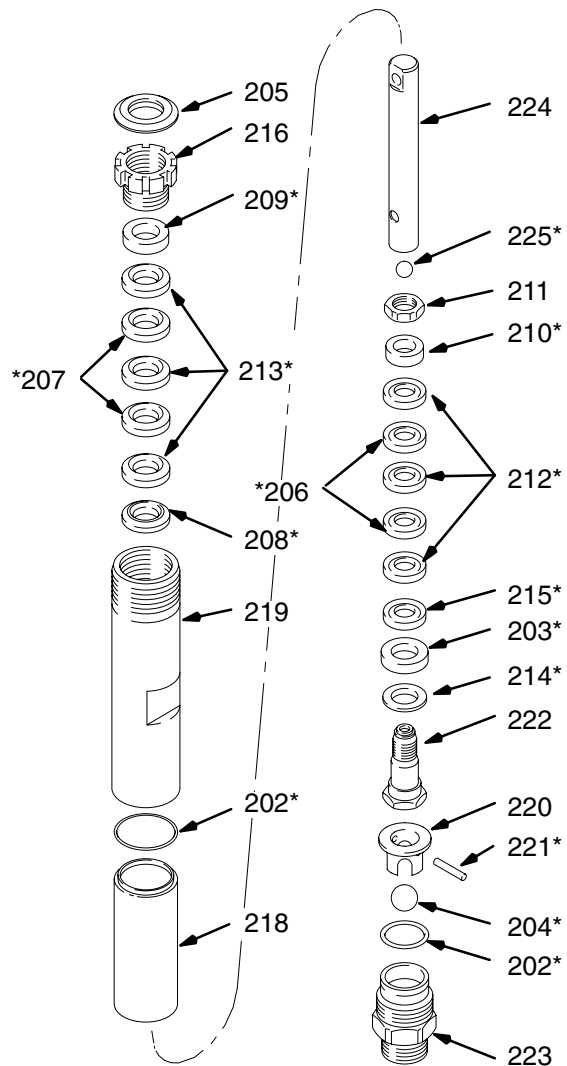

01198

Parts Drawing – Pressure Control

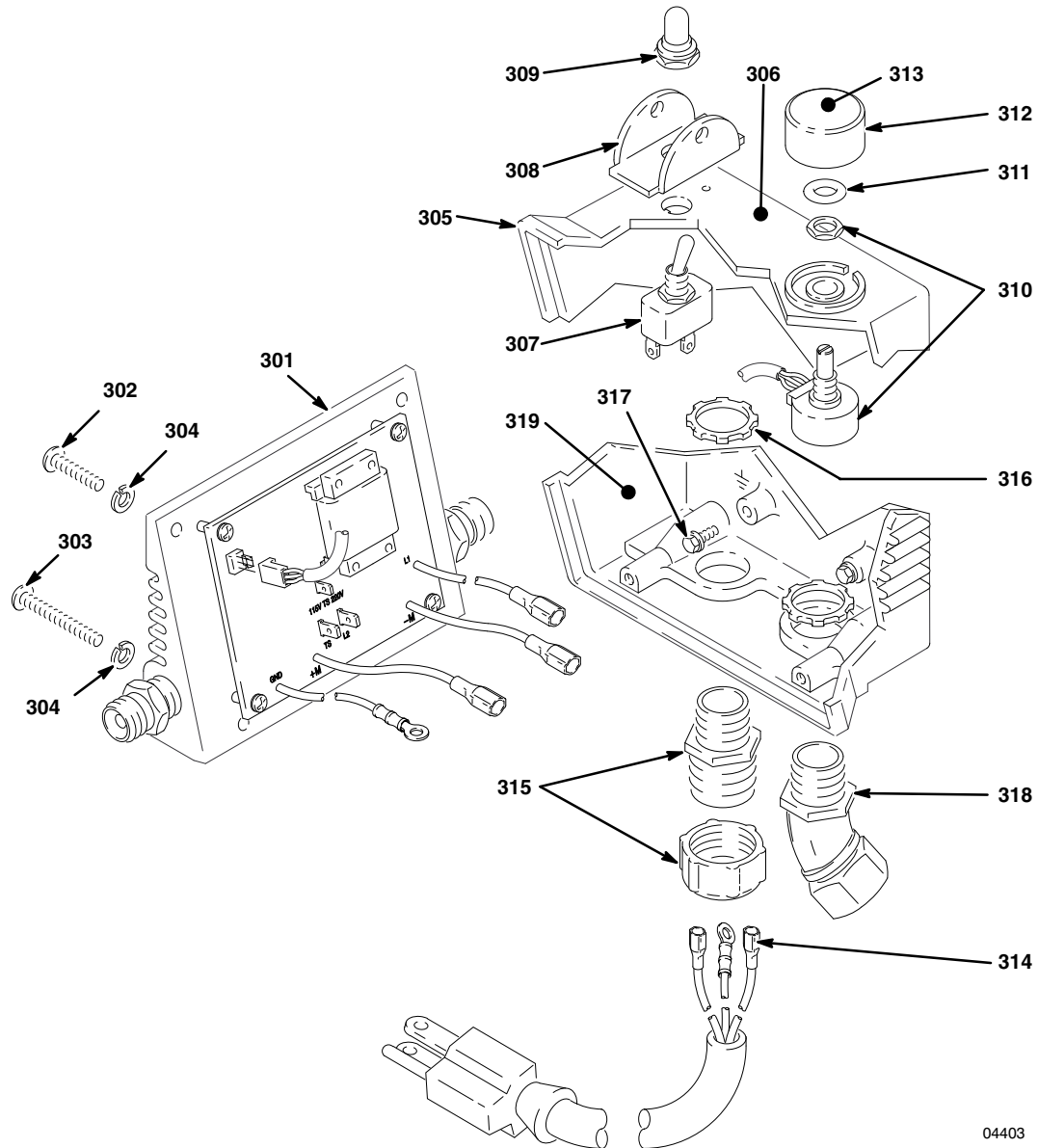

04403

Parts List – Pressure Control

Basic Pressure Control for the ULTIMATE) Plus+ 1000 Sprayers

| REF NO. | PART NO. | DESCRIPTION | QTY | REF NO. | PART NO. | DESCRIPTION | QTY |
|---------|----------|------------------------------------|-----|---------|----------|-----------------------------|-----|
| 301 | 820-221 | BOARD, pressure control | 1 | 311 | 820-491 | SEAL, shaft | 1 |
| 302 | 821-043 | SCREW, panhead, 10-24 x 1" | 2 | 312 | 821-046 | KNOB, control | 1 |
| 303 | 821-044 | SCREW, panhead, 10-24 x 2" | 2 | 313 | 820-646 | LABEL, knob | 1 |
| 304 | 820-589 | WASHER, lock, #10 | 4 | 314 | 821-047 | CORD, power | 1 |
| 305 | 821-045 | HOUSING, cast | 1 | 315 | 820-527 | BUSHING, strain relief | 1 |
| 306 | 290-034* | LABEL, caution | 1 | 316 | 821-048 | LOCKNUT | 1 |
| 307 | 820-342 | SWITCH, toggle | 1 | 317 | 821-049 | SCREW, hexhead, 8-24 x .375 | 1 |
| 308 | 820-433 | GUARD, locking | 1 | 318 | 820-507 | CONNECTOR, conduit | 1 |
| 309 | 820-341 | BOOT, switch | 1 | 319 | 189-286* | LABEL, warning | 1 |
| 310 | 820-999 | POTENTIOMETER, pressure adjustment | 1 | | | | |

*Extra Warning and Caution labels are available free.

Wiring Diagram

PRESSURE CONTROL BOARD/COVER 820-221

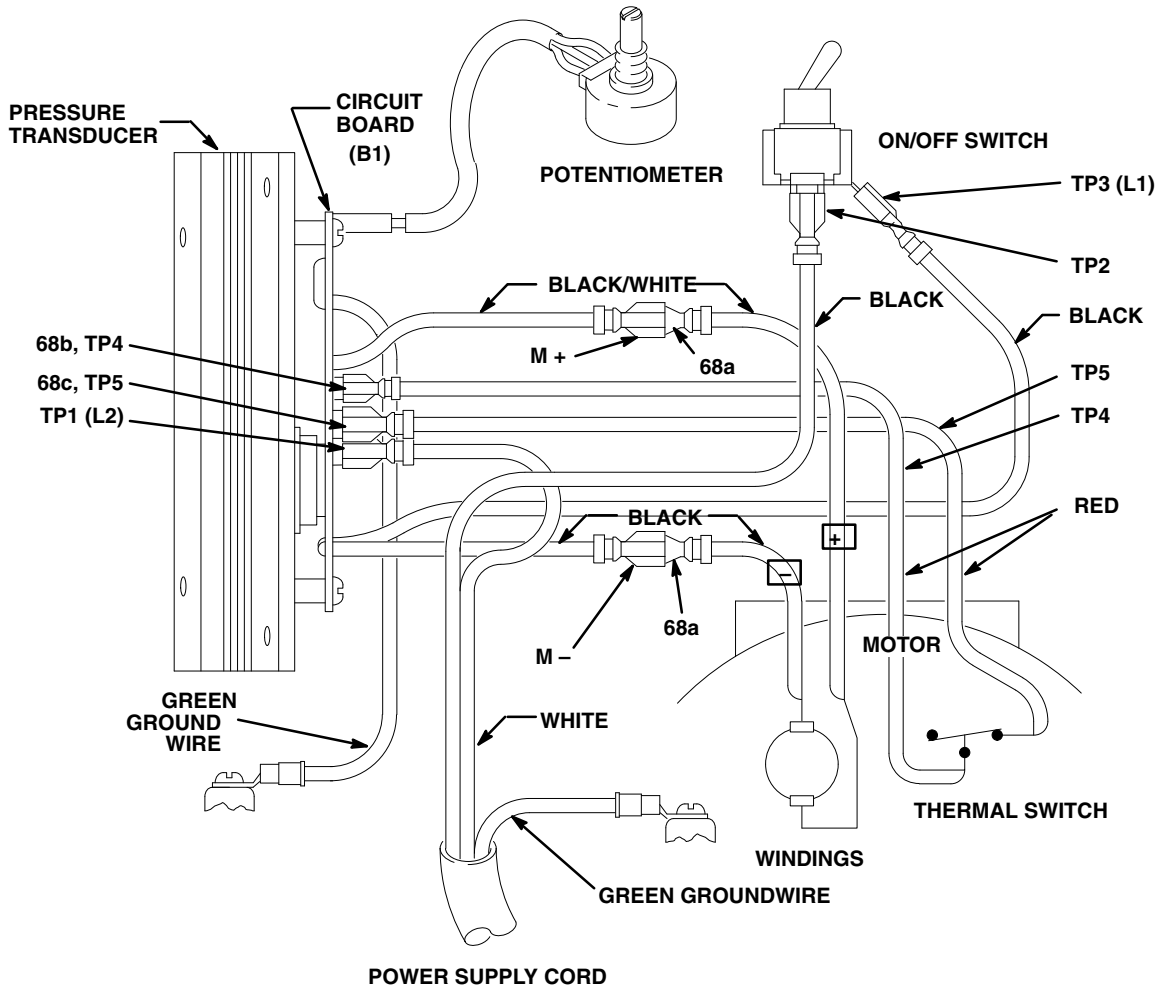

04296

Fig. 33

Accessories

DANGER LABELS

The English language DANGER label shown on page 1 and the same label in French are on your sprayer. If you have painters who do not read English or French, order one of the following labels to apply to your sprayer. The drawing below shows the best placement of these labels for good visibility. Order the labels directly from Graco, free of charge.

Toll Free: 1-800-328-0211

French 185-956
Spanish 185-961
German 186-041
Greek 186-045
Korean 186-049
English 185-593

Apply other language here

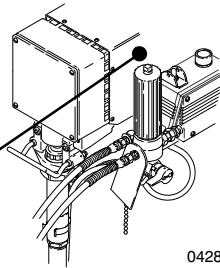

04287

SPRAY GUN 820-076
 5000 psi (350 bar) Maximum Working Pressure

Includes two guns.

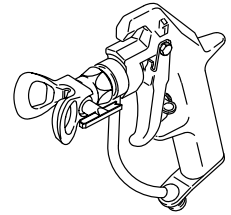

SPRAY GUN 820-077
 5000 psi (350 bar) Maximum Working Pressure

Has filter in handle.
 Includes two guns.

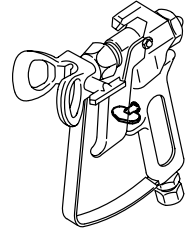

SPRAY GUN 820-078
 3600 psi (248 bar) Maximum Working Pressure

Includes two guns.

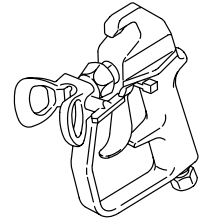

Technical Data

Power Requirements 120 VAC, 60Hz,
 1 phase, 15 amp minimum or 3500 Watt generator
 Motor 1HP DC
 Working Pressure Range 0-3000 psi (0 - 210 bar)
 Cycles/Gallon (liter) 200(53)
 Maximum Delivery 1.0 GPM (3.8 liter/min)
 Tip Size one gun -0.031; two guns-0.019
 (with latex at 2000 psi (138 bar)
 Power Cord No. 14 AWG, 3 wire, 8'6" (2.6 m)
 Inlet Paint Strainer 16 mesh (1190 micron)
 Stainless Steel Screen, reusable
 Outlet Paint Filter 60 mesh (250 micron)
 Stainless Steel Screen, reusable
 Pump Inlet Size 3/4 npt(m) with 30° ID chamfer
 Fluid Outlet Size 1/4 npsm from fluid filter
 Wetted Parts:
Displacement Pump Carbon steel, Polyurethane,
 Delrin®
Packing Material Leather, UHMW polyethylene
Filter Aluminum, Carbon steel, Stainless Steel
 60 mesh (250 micron) reusable SST screen

NOTE: Delrin®

Dimensions

Weight (dry w/o packaging) 95 lb (43 Kg)
 Height 28 in. (711 mm)
 Length 26 in. (660 mm)
 Width 22.5 in. (572 mm)

THE SHERWIN-WILLIAMS ULTIMATE® WARRANTY AND DISCLAIMERS

The Sherwin-Williams Company warrants the Ultimate sprayers to be free from defects in material and workmanship on the date of sale to the original purchaser for use. As purchaser's sole remedy for breach of this warranty, The Sherwin-Williams Company will, for a period of twelve months from the date of sale, repair or replace any part of the equipment proven defective, with the exception of defects in parts of the drive train/gear box on which will be repaired or replaced for forty-eight months from the date of sale and the electric motor (excluding brush replacement) or pressure control assembly which will be repaired or replaced for twenty-four months from date of sale. This warranty applies only when the equipment is installed, operated and maintained in accordance with The Sherwin-Williams' Company written recommendations.

This warranty does not cover, and The Sherwin-Williams Company shall not be liable for, any malfunction, damage or wear caused by faulty installation, misapplication, abrasion, corrosion, inadequate or improper maintenance, negligence, accident, tampering, or substitution of non-original equipment manufacturer component parts. Nor shall The Sherwin-Williams Company be liable for malfunction, damage or wear caused by the incompatibility with Sherwin-Williams equipment of structures, accessories, equipment or materials not supplied by The Sherwin-Williams Company, or the improper design, manufacture, installation, operation or maintenance of structures, accessories, equipment or materials not supplied by The Sherwin-Williams Company.

This warranty is conditioned upon the prepaid return of the equipment claimed to be defective to an authorized Sherwin-Williams sales/service outlet for verification of the claimed defect. If the claimed defect is verified, The Sherwin-Williams Company will repair or replace free of charge any defective parts. The equipment will be returned to the original purchaser transportation prepaid. If inspection of the equipment does not disclose any defect in material or workmanship, repairs will be made at a reasonable charge, which charges may include the costs of parts, labor, and transportation.

Disclaimers and Limitations. The terms of this warranty constitute purchaser's sole and exclusive remedy and are in lieu of any other warranties (express or implied), including warranty of merchantability or warranty of fitness for a particular purpose, and of any non-contractual liabilities, including product liabilities based on negligence or strict liability. Every form of liability for direct special or consequential damages or loss is expressly excluded and denied. In no case shall The Sherwin-Williams Company liability exceed the amount of the purchase price.